



EXCEL LIFE SMART



ARTEOR WITH NETATMO



LIVING NOW WITH NETATMO

HOMEOWNER STARTER GUIDE

YOU'RE ONLY A FEW STEPS AWAY FROM TURNING YOUR NEW HOME INTO A SMART HOME!

WE'VE FITTED YOUR HOME WITH LEGRAND SMART SWITCHES AND SOCKETS.



EXCEL LIFE SMART



ARTEOR WITH NETATMO



LIVING NOW WITH NETATMO



Product wiring and install



Pre-configuration

These products have been pre-configured for you, but a few more steps are necessary to complete your Smart Home installation.

Your turn!

To complete the installation you will need:

- 1. Smartphone or tablet**
- 2. Wi-Fi internet connection**

NOW, FOLLOW THE NEXT EASY STEPS

If you have any further questions, please call Legrand on 1300 369 777 (Monday-Friday, 8am to 5pm AEST) and we would be happy to assist you through the set up.



STEPS



Download the Home + Control App



Create an account



Set up the installation



Share your installation with others

LETS GET STARTED

1 DOWNLOAD THE HOME + CONTROL APP



FREE DOWNLOAD



1. Go to App store or Google Play store.

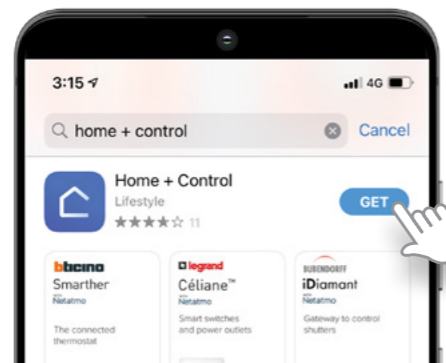

2. Search "Legrand Home+Control".



3. Download the app.

2 CREATE AN ACCOUNT



1. Launch the Home+Control app.

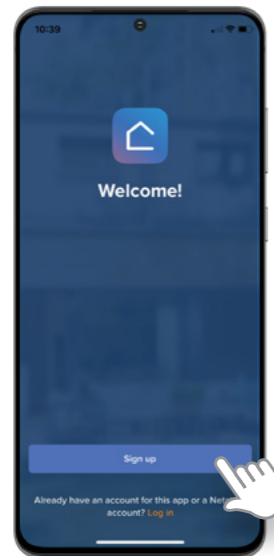

2. Click on "Sign up" at the bottom of the screen.

Note: If you already own a Netatmo camera or weather station, or a Bticino Classe100X or Classe300EOS Wi-Fi intercom, click on "Log in". Enter the same credentials as used in the app for those products.



3. Enter your email address.



4. Choose a password meeting all criteria listed. Once logged in, press "Start".

3 SETUP

WHICH GATEWAY IS INSTALLED IN YOUR HOME?

The Gateway with Home/Away Switch is installed on a wall plate, generally in a central place not far from your internet modem.

The Gateway module is installed inside your electrical load centre or distribution board.

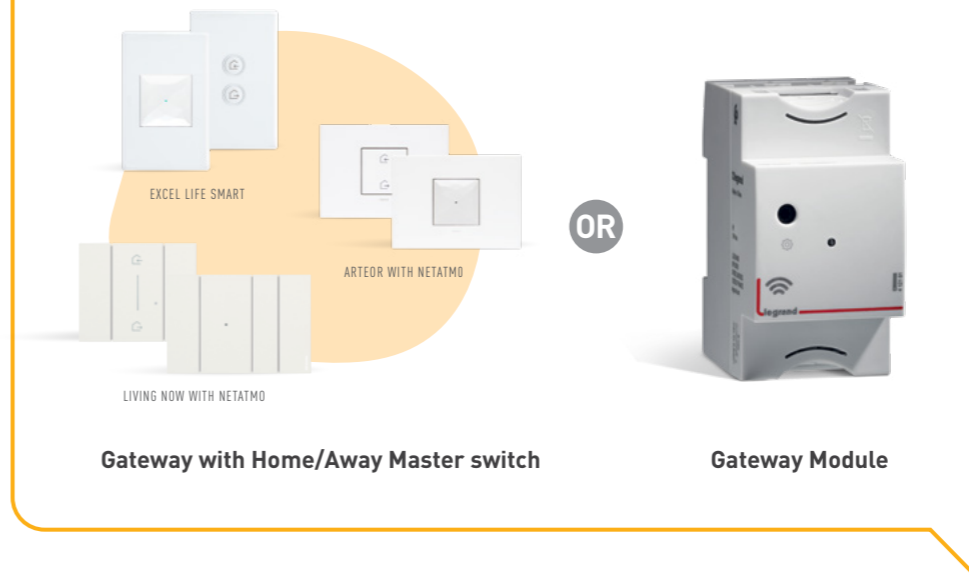

1. "Select Legrand" then the type of Gateway installed.

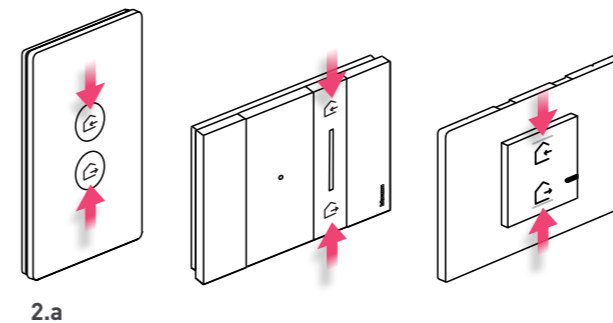

2.a

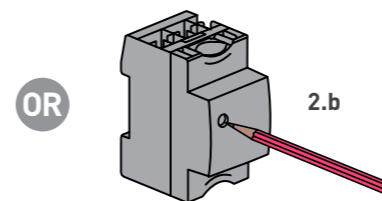

OR

2.b

2. If you have a Gateway with Home/Away master switch: Press and hold the 2 buttons of the Home/Away switch (the one with the 2 house icons) until it flashes green then release immediately. See 2.a.

If you have the Gateway module: Use a pen/small screwdriver to press and hold the front button (recessed black spot) until the front indicator flashes green then release immediately. See 2.b.

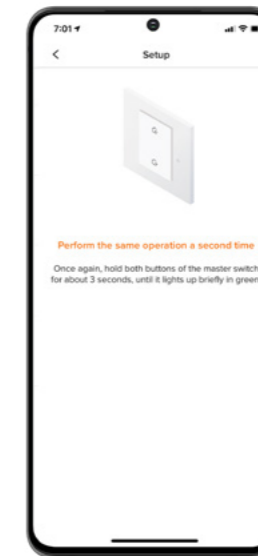

3. Repeat Step 2 again.



4. Choose a name for your smart home. The app will start pairing your Gateway to your Wi-Fi network. Confirm when prompted.

HOME + CONTROL APP:

3 SETUP (continued)



5. Use your camera to scan the **Apple HomeKit 8-digit code**

If you have a Gateway with Home/Away switch: It is at the back of the Home/Away switch.
If you have a gateway module: It is at the front of the Gateway module.



6. Wait for setup to be completed and firmware updates to be downloaded. This can take up to 5-10mins. Click **"Next"**.



7. Click **"Start"** and go to one of the rooms where your first smart product is located.

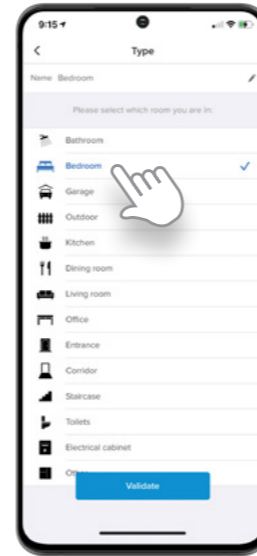

8. Select the type of room you are in and click **"Validate"**.

3 SETUP (continued)



13. When all rooms and smart products are allocated, press **"Finish"**. Review your full installation and click **"Finish"**.

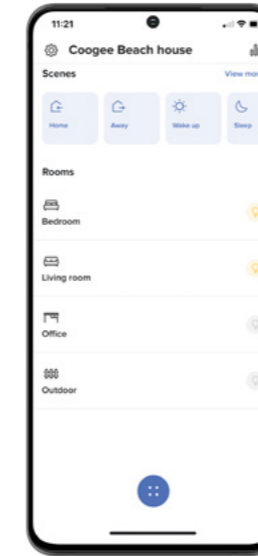

14. You can now control your lights and electrical appliances in the main menu. Select the bulb next to the room name to switch ON/OFF all smart products in this room, or select the room name to see each smart product in this room and operate them independently.

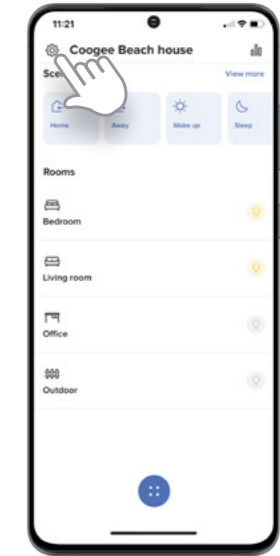
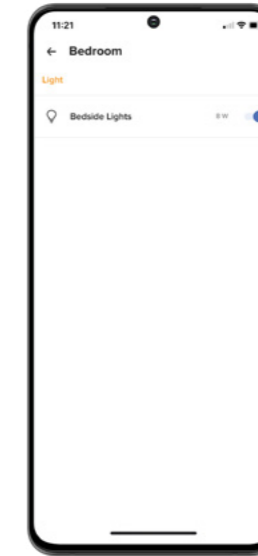

TIP: Scenarios are available at the top of your Home+Control app screen, schedules can be accessed via the blue circle at the bottom of the screen. Both scenarios and schedules can be customised in the **"Settings menu"**.

4 SHARE YOUR INSTALLATION WITH LOVED ONES AND OTHERS



9. Press the smart products you want to configure. They will then show up in the app. Click on the product frame to see the details.

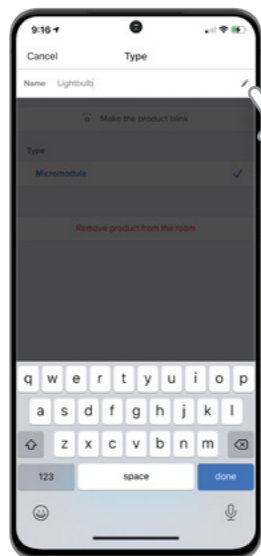

10. Rename the products by clicking on the pen symbol.



11. Click **"Done"**, once all the products in this room have been detected and renamed.

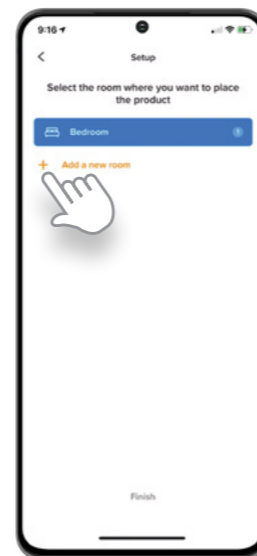

12. Click **"Add a new room"** and move to the next room where you have smart products installed. Repeat steps 8 to 11.

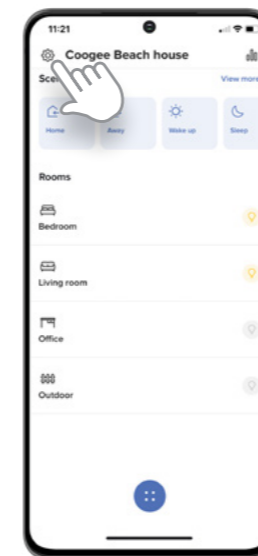

1. Click on **"Settings"**.

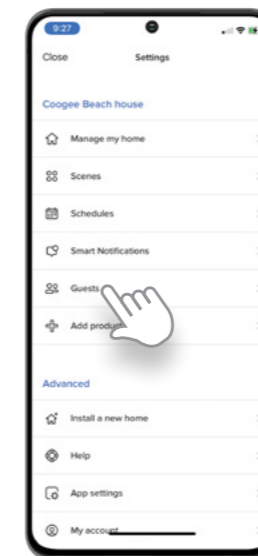

2. Select **"Guests"**.

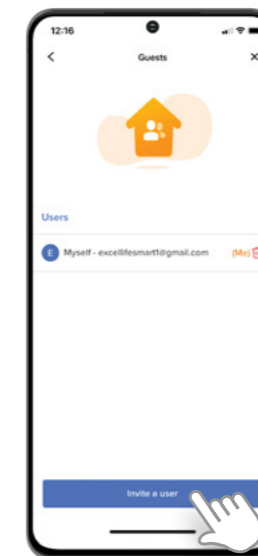

3. Select the person you want to invite and the digital method to send the invitation. (Email, text message, social chat messages, etc.)

SCAN QR CODE FOR
ADDITIONAL SUPPORT



STICK YOUR APPLE HOMEKIT SETUP CODE HERE



OR

WRITE YOUR 8 DIGIT CODE IN THE BOXES BELOW

--	--	--	--	--	--	--	--



Legrand Australia
Building 4 Nexus Industry Park
43-47 Lyn Pde Prestons NSW 2170
1300 369 777
www.legrand.com.au

Legrand New Zealand
106-124 Target Road Glenfield
Auckland 0627 New Zealand
0800 476 009
www.legrand.co.nz