

FISHER & PAYKEL

GAS COOKTOP

CG604C & CG905C models

INSTALLATION GUIDE / USER GUIDE

NZ AU

CONTENTS

Safety and warnings	2
Installation instructions	6
Introduction	14
Using your cooktop	15
Cooking guidelines and cookware	18
Care and cleaning	20
Troubleshooting	24
Warranty and service	26

IMPORTANT! **SAVE THESE INSTRUCTIONS**

The models shown in this user guide may not be available in all markets and are subject to change at any time. For current details about model and specification availability in your country, please go to our website www.fisherpaykel.com or contact your local Fisher & Paykel dealer.

SAFETY AND WARNINGS

Your safety is important to us. Please read this information before using your cooktop.

Installation

WARNING!



Electrical Shock Hazard

Before carrying out any work on the electrical section of the appliance, it must be disconnected from the mains electricity supply.

Connection to a good earth wiring system is absolutely essential and mandatory.

Alterations to the domestic wiring system must only be made by a qualified electrician.

Failure to follow this advice may result in electrical shock or death.

WARNING!



Cut Hazard

Beware of sharp edges when handling stainless steel appliances.

Failure to use caution could result in injury or cuts.

IMPORTANT SAFETY INSTRUCTIONS!

Installation

- Read these instructions carefully before installing or using this product.
- Please make this information available to the person responsible for installing the product as it could reduce your installation costs.
- Particular attention shall be given to the relevant requirements regarding ventilation.
- This appliance is to be installed and serviced only by an authorised person.
- Installation must comply with your local building and local gas authority codes and electricity regulations.
- Incorrect installation, for which the manufacturer accepts no responsibility, may cause personal injury or damage and could invalidate any warranty or liability claims.
- These appliances are registered in: New Zealand at www.energysafety.govt.nz and Australia with Australian Gas Association at www.aga.asn.au.
- Appliances are factory set for either Natural gas or ULPG. If in doubt, refer to the local gas network operator or gas supplier to confirm gas type at installation site.
- This appliance must be installed in accordance with these installation instructions and in compliance with local gas fitting regulations, municipal building codes, water supply regulations, electrical regulations, AS5601/AG601 and NZS5261 - Gas installations and any other relevant statutory regulations.
- Do not modify this appliance.
- When this appliance is installed, it shall not be used as a space heater.
- Do not use or store flammable materials on or near this appliance.
- Do not spray aerosols in the vicinity of this appliance while it is in operation.
- This appliance should not be sealed into the bench with silicone or glue. Doing so will make future servicing difficult. Fisher & Paykel will not be liable for any costs associated with removing or replacing a sealed-in product, nor for repairing any damage that may be incurred by doing this. Fisher & Paykel does not exclude any statutory liability it may have and which by law cannot be excluded, because of the giving of this notice.
- If the appliance is connected to the gas supply with a flexible hose, make sure that the hose cannot come in contact with the bottom of the appliance or any sharp edges.
- Ensure that the electrical connection plug is accessible after installation.
- Packing elements (eg plastic bags, polystyrene foam, staples, packing straps etc) and tools should not be left around during and after installation, especially if they are within easy reach of children, as these may cause serious injuries.

SAFETY AND WARNINGS

Operation and maintenance

WARNING!



Fire Hazard

Never leave the appliance unattended when in use. Boilover causes smoking and greasy spillovers that may ignite.

Never use your appliance for warming or heating the room. Failure to follow this advice may result in serious injury.

WARNING!



Explosion Hazard

Do not use or store flammable materials such as gasoline near this appliance. Do not spray aerosols in the vicinity of this appliance while it is in operation.

Failure to follow this advice may result in death or serious injury.

WARNING!



Hot Surface Hazard

This appliance becomes hot during use.

Do not touch the cooktop components, burners, trivets, pan supports or the base when hot.

Before cleaning, turn the burners off and make sure the whole cooktop is cool.

Failure to follow this advice may result in serious injury.

WARNING!



Electrical Shock Hazard

Switch the power to the cooktop off at the wall before cleaning or maintenance.

Failure to follow this advice may result in death or electrical shock.

WARNING!



Poisoning Hazard

Never use this appliance as a space heater to heat or warm the room.

Doing so may result in carbon monoxide poisoning and overheating of the appliance.

Failure to follow this advice may result in poisoning or death.

IMPORTANT SAFETY INSTRUCTIONS!

Operation and maintenance

- Keep children away from the cooktop when it is in use.
- Household appliances are not intended to be played with by children.
- Children of less than 8 years old must be kept away from the appliance unless continuously supervised. This appliance can be used by children aged from 8 years and above, and persons with reduced physical, sensory or mental capabilities or lack of experience and knowledge, if they have been given supervision or instruction concerning the use of the appliance in a safe way and they understand the hazards involved. Cleaning and user maintenance shall not be done by children without supervision.
- If the electrical supply cord is damaged, it must only be replaced by an authorised person. Ensure that the electrical connection plug is accessible after installation.
- This appliance should be connected to a circuit that incorporates an isolating switch providing full disconnection from the electricity supply.
- Do not use an asbestos mat or decorative covers between the flame and the saucepan as this may cause serious damage to your cooktop.
- Do not place aluminium foil or plastic dishes on the cooktop burners.
- Do not let large saucepans or frying pans overlap the bench as this can deflect heat onto your benchtop and damage the surface.
- Do not let large saucepans, frying pans or woks push any other pans aside. This could make them unstable or deflect heat onto your benchtop and damage the surface.
- Do not use a steam cleaner for cleaning this cooktop.
- Saucepan handles may be hot to touch. Ensure saucepan handles do not overhang other gas burners that are on. Keep handles out of reach of children.
- Do not stand or place heavy objects on this appliance.
- After use, ensure that the control dials are in the 'OFF' position.
- This appliance shall not be used as a space heater, especially if installed in marine craft or caravans.
- The use of a gas cooking appliance results in the production of heat and moisture in the room in which it is installed. Ensure the kitchen is well ventilated. Keep natural ventilation holes open or install a mechanical ventilation device (mechanical extractor hood). Prolonged intensive use of the appliance may call for additional ventilation, for example opening of a window, or more effective ventilation, for example increasing the level of mechanical ventilation where present.
- After having unpacked the appliance, check to ensure that it is not damaged.
- In case of doubt, do not use it and consult your supplier or a professionally qualified technician.
- Packing elements (eg plastic bags, polystyrene foam, nails, packing straps, etc.) should not be left around within easy reach of children, as these may cause serious injuries.
- Some appliances are supplied with a protective film on steel and aluminium parts. This film must be removed before using the appliance.

INSTALLATION INSTRUCTIONS

Cooktop and cutout dimensions

Drawings for illustration purposes only

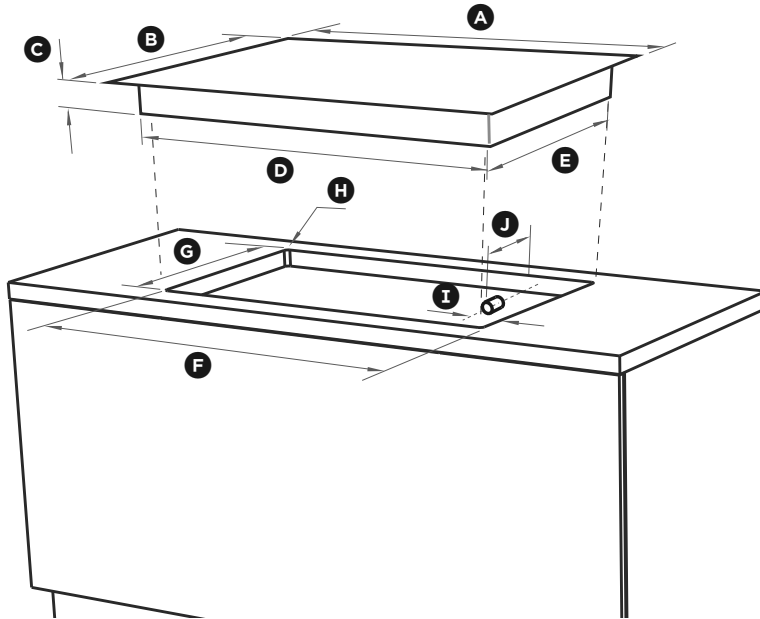

PRODUCT AND CUTOUT DIMENSIONS

	CG604C	CG905C
	MM	MM
(A) Overall width of cooktop	578	914
(B) Overall depth of cooktop	511	533
(C) Height of chassis (below top of bench)	54	54
(D) Width of chassis	558	840
(E) Depth of chassis	473	473
(F) Overall width of cutout	560	870
(G) Overall depth of cutout	490	494
(H) Corner radius of cutout	max. 10	max. 10
(I) Distance from right edge of cutout to manifold centre line	21	35
(J) Distance from rear edge of cutout to gas inlet	40	40

INSTALLATION INSTRUCTIONS

Clearances

Drawings for illustration purposes only

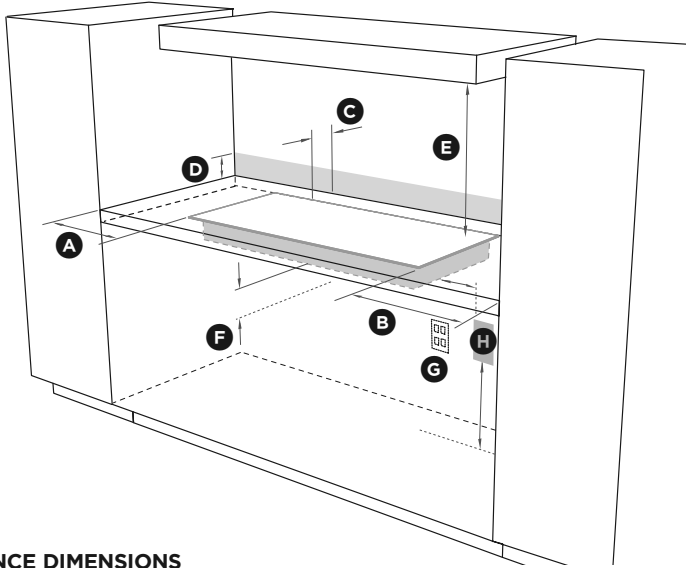

CLEARANCE DIMENSIONS

	CG604C	CG905C
	MM	MM
(A) Minimum clearance from left edge of cutout to: nearest combustable surface	140	140
(B) Minimum clearance from right edge of cutout to: nearest combustable surface	140	140
(C) Minimum clearance from rear edge of cutout to: nearest combustable surface nearest non-combustable surface	112 20	112 30
(D) Minimum height of non-combustable material when used on adjacent walls (See section 'Standards requirements' following)	150	150
(E) Minimum clearance from pan supports to: rangehood any other overhead exhaust fan downward-facing combustable surface (overhead cabinetry) downward-facing tiled or fire-resistant surface	650 800 650 500	650 800 650 500
(F) Minimum clearance below top of benchtop to: nearest combustable surface F&P oven or nearest non-combustable surface	60 60	60 60
(G) Ensure there is an earthed power outlet within 900mm of the rear right- hand corner of the cooktop. The outlet should be accessible with the cooktop installed.		
(H) If connecting the cooktop to the gas supply with a flexible hose, the connector on the wall should be between 800-850mm above the floor and to a distance of at least 250mm outside the width of the cooktop. The connector should be accessible with the cooktop installed.		

INSTALLATION INSTRUCTIONS

Before you start

Before starting to install the cooktop, make sure that:

- the cooktop has not been damaged during transport. In case of doubt after unpacking and checking it, contact the retailer
- the local distribution conditions (nature of gas and pressure) and the adjustment of the cooktop (as detailed on the appliance data label and in the 'Gas rate and injector size table' further below) are compatible
- the cooktop will be connected to a 220-240 V 50 Hz power supply and earthed via the power supply cable
- there is an earthed power outlet within the reach of the cooktop's power supply cable (within 900mm from the rear right of the cooktop, see dimension G in 'Clearances')
- the power outlet will be accessible after installation
- the power supply cable will not touch any hot or metal parts
- a suitable isolating switch providing full disconnection from the mains power supply is incorporated in the permanent wiring, mounted and positioned to comply with local wiring rules and regulations. The isolating switch must be of an approved type and provide a 3mm air gap contact separation in all poles (or in all active [phase] conductors if the local wiring rules allow for this variation of the requirements)
- the isolating switch will be accessible after installation
- the benchtop is made of a heat-resistant material
- exposed bare edges of the cutout are sealed with an oil-based paint or moistureproof polyurethane to prevent possible damage from moisture creeping between the cooktop trim and the benchtop.

Standards requirements

Temperature of nearby surfaces. Australian and New Zealand Gas Installation Standards (AS/NZS 5601.1 current edition) require a cooktop to be installed so that the surface temperature of any nearby combustible surface will not exceed 65°C above ambient. This is typically achieved by:

- having the cooktop spaced away from the wall (see dimensions A, B, and C in 'Clearances') OR
- protecting the wall to a height of at least 150 mm along its length (see dimension D in 'Clearances') with non-combustible surface materials such as:
 - 5 mm-thick ceramic tiles—these alone are adequate
 - tempered glass or sheetmetal (minimum thickness 0.4mm)—acceptable when used in front of a fire resistant material
 - F&P splashback (not available in Australia) when used with a 10mm clearance from the rear edge of the cooktop to the front of the splashback (SB90 and SB1216 splashback models only).

Note: these cooktops have been tested by an independent testing lab and meet standards requirements when installed to the dimensions in these instructions.

INSTALLATION INSTRUCTIONS

Fastening the cooktop to the bench

This cooktop is supplied with fastening brackets (and screws) that will cope with a bench thickness of 20-50mm. For benches thicker than 50mm, recess the underside to a thickness of 20-50mm.

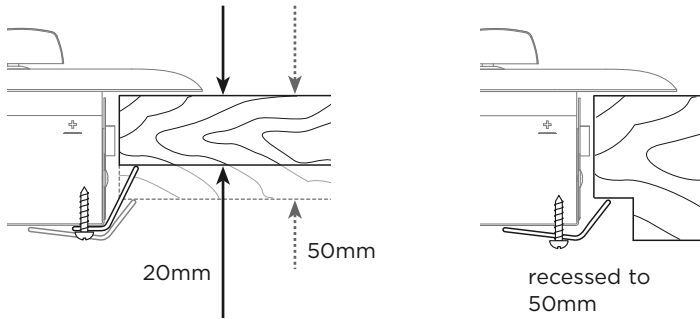

Fastening the cooktop to the bench

Connecting the cooktop to the gas supply

IMPORTANT!

- **This cooktop is supplied factory-set for either Natural Gas or ULPG. Please ensure that the factory-set adjustment of the cooktop is compatible with the local distribution conditions (nature of gas and pressure).**
- **The gas connection must be carried out by a suitably qualified person according to the relevant standards.**
- For Natural Gas, connect the gas supply to the gas pressure regulator supplied with the cooktop. Adjust the regulator to obtain a test point pressure of 1 kPa (4" W.C.) with the three largest burners operating at the highest setting.
- For ULPG, connect the the gas supply to the test point adaptor supplied with the cooktop. Ensure that the supply pressure is regulated to 2.75 kPa (11" W.C.)
- Make sure the connection point will be accessible with the cooktop installed.
- To enable the gas supply to be readily shut off, make sure the connection is fitted with an isolating valve close to the cooktop.
- Attach the duplicate appliance data label on a surface adjacent to the cooktop, so that it will be easily read with the cooktop installed.
- Gas connection to these cooktops **MUST** use the elbow supplied. The regulator will not seal if installed without it.
- Ensure the fibre washer (supplied) is located between the elbow (supplied) and cooktop gas inlet. Failure to use this washer will cause the connection to leak. Tighten the floating nut to firm finger tight, plus an additional 1/4 turn (90°).

INSTALLATION INSTRUCTIONS

Gas connection with a flexible hose

- If the gas is connected with a flexible hose, the connector on the wall should be between 800-850mm above the floor and to a distance of at least 250mm outside the width of the cooktop. The connector should be accessible with the cooktop installed.
- Flexible hose assemblies should be AS/NZS 1869 Class B or Class D certified. The thread connection shall be Rp 1/2" (ISO 7-1) female.
- The hose assembly must be as short as practicable and comply with relevant AS 5601/ NZS 5261 requirements.
- The hose must not be kinked, subjected to abrasion or permanently deformed.
- The hose must not be near or in contact with any hot surfaces (eg base of metal hotplate, flue or chassis of underbench oven etc).

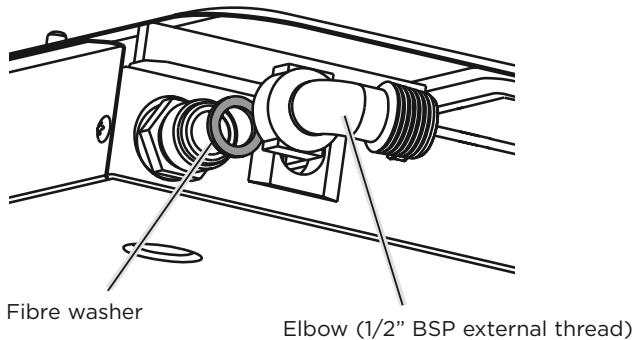

Gas connection to the cooktop

INSTALLATION INSTRUCTIONS

Leak-testing and flame-testing the cooktop

IMPORTANT!

The operation of the cooktop, including the ignition system, must be tested before installation is complete. If, after following the instructions below, satisfactory performance cannot be obtained, contact the local gas authority or your local Authorised Repairer for advice and assistance.

Checking the connections for leaks

After installation and making all connections, check thoroughly for possible leaks and make sure all connections are gas-tight.

- ① Turn all control dials to O (OFF).
- ② Open the valve on the gas supply.
- ③ Check each connection one at a time by brushing a soap and water solution or a suitable leak detection fluid over it.

IMPORTANT!

Do not use any naked flames to check for leaks.

- The presence of bubbles indicates a leak. Tighten or replace connections as appropriate, then leak-test all connections again. Ensure the fibre washer (supplied) is located between the elbow and the cooktop's gas inlet.

Checking the burner flames

- ① Light each burner.
 - ② Check for a well-defined blue flame without any yellow tipping.
- If any abnormality is evident, check that:
 - the burner cap is located properly
 - the injector nipple is correctly aligned
 - the correct size injectors are installed.

Incorrect: flame
'lifting off' the burner

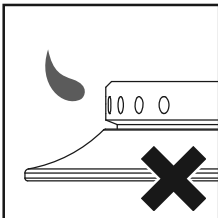

Incorrect:
yellow tipping

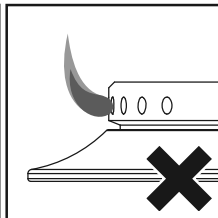

Good flame: well-defined blue
flame without yellow tipping

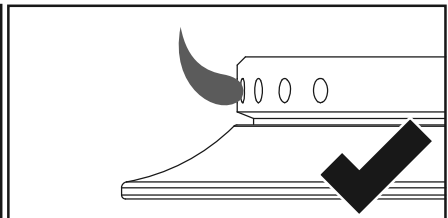

Incorrect and good flame patterns

INSTALLATION INSTRUCTIONS

Gas rate and injector size table

	NATURAL GAS		ULPG	
Test point pressure (kPa)	1.0		2.75	
Burners	Injector orifice size (mm)	Nominal gas rate (MJ/h@1kPa)	Injector orifice size (mm)	Nominal gas rate (MJ/h@2.75kPa)
CG604C, CG905C				
Auxiliary right front	0.85	3.6	0.55	4.0
Semi-rapid left & right rear	1.30	8.5	0.80	8.5
Wok CG604C: left front CG905C: left front & centre	1.75	15.0	1.00	13.5

INSTALLATION INSTRUCTIONS



TO BE COMPLETED BY THE INSTALLER

- Have you securely fastened the cooktop to the bench with the supplied brackets?
- Have you used the supplied elbow and fibre washer to connect the gas to the inlet on the cooktop?
- Have you leak-tested all connections?
- Are the injector sizes correct for the gas type?
- Is the shut-off valve on the gas supply accessible to the customer?
- Is the power supply isolating switch accessible to the customer?
- Is the cooktop power supply cable plugged into an earthed outlet?
- Check the entire length of the power supply cable: it should not touch any hot metal parts.
- Have you removed all protective film from the stainless steel surfaces?
- Have you disposed of all packaging elements?

OPERATION:

- Do all burners light individually and in combination?
- Do the burners remain lit when turned quickly from maximum to minimum?
- Are the flames consistent, free from any yellow tipping and appropriately sized?
- Have you demonstrated the basic operation to the customer?

Complete and keep for safe reference:

Model

Serial No.

Purchase Date

Purchaser

Dealer Address

Installer's Name

Installer's Signature

Installation Company

Installation Date

INTRODUCTION

About your new cooktop

Thank you for buying a Fisher & Paykel gas cooktop. Once it is installed and ready to use, you will want to know everything about it to make sure you get excellent results right from the start.

We recommend you read the whole guide before using your new cooktop, for both safety and cooking success.

For more information, visit our local website listed on the back cover.

Before using your new cooktop

- Read this user guide, taking special note of the 'Safety and warnings' section.
- Ensure the power supply to the cooktop is turned on.

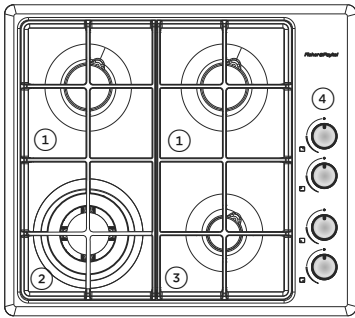

Cooktop layout - CG604C models

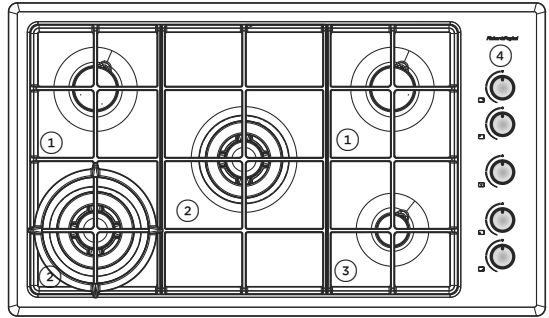

Cooktop layout - CG905C models

- ① Semi-rapid burner
- ② Wok burner
- ③ Auxiliary burner
- ④ Control dials

USING YOUR COOKTOP

Control dials

The dials control the flow of gas through the valve.

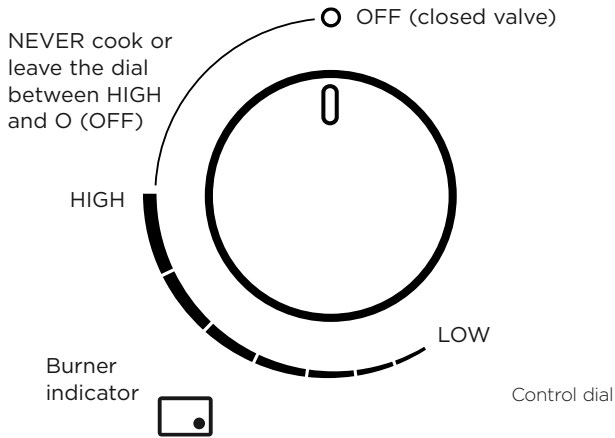

Using the burners

- ① Press the selected burner's dial down gently and turn it anti-clockwise to HIGH.
 - The ignitors on all the burners will spark.
- ② Hold down the dial for about 5 seconds after the burner has lit. Releasing the dial too soon will extinguish the flame.
- ③ Adjust the flame anywhere between HIGH and LOW. Do not adjust between HIGH and O (OFF).
- ④ After use, always turn the dials to O (OFF).

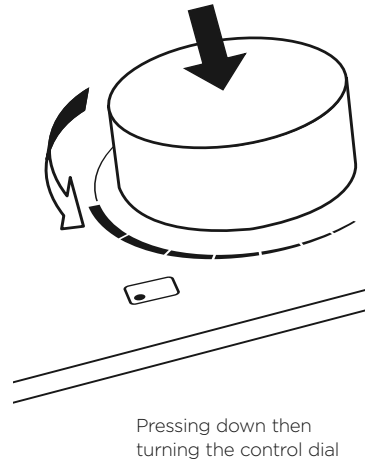

USING YOUR COOKTOP

If a burner does not light

Turn the control dial to O (OFF) and wait at least 1 minute before trying again. This is to allow the gas to disperse. If after trying again the burner still does not light, check that:

- the cooktop is plugged in and the power supply is switched on
- there is no power failure in your home or neighborhood
- the gas is turned on
- the gas bottle is not empty (if you use bottled gas)
- the ignitors are sparking. If they are not sparking, they may be dirty or wet. Clean them with a toothbrush and methylated spirits, as shown in below. See 'Care and cleaning' for instructions on removing and replacing the burner parts.

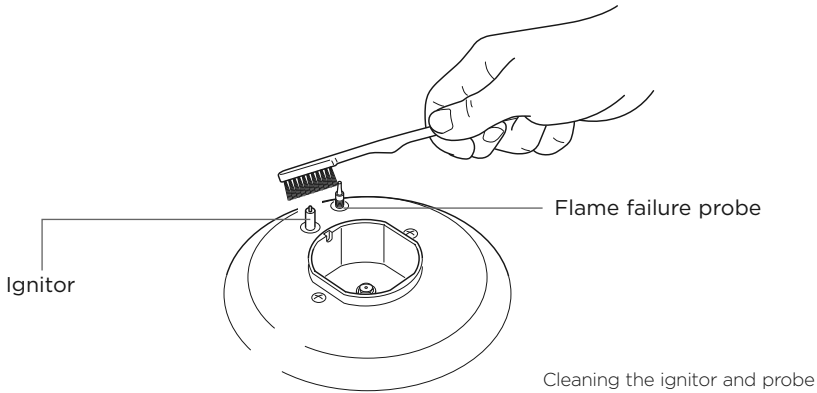

If the flame is irregular

Check that the burner parts (flame spreader and burner cap) are:

- clean and dry
- positioned correctly, as shown below.
- For further advice, see sections 'Care and cleaning' and 'Troubleshooting'.

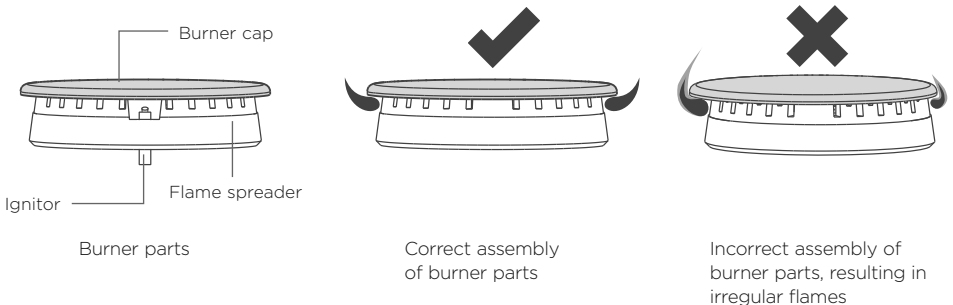

USING YOUR COOKTOP

If there is a power failure

- You can still use your cooktop.
- Light the burners by holding a match close to the side of the burner and turning the control dial to HIGH. Wait until the flame is burning evenly before adjusting.

If the flame is accidentally extinguished

The flame failure protection will automatically cut the gas supply to the burner off. Turn the corresponding dial to O (OFF) and do not try to relight it for at least 1 minute (to allow the gas to disperse).

COOKING GUIDELINES AND COOKWARE

Cooking guidelines

IMPORTANT!

- **Never leave the cooktop unattended when in use. Boilover causes smoking and greasy spills that may ignite.**
- **Take care when deep-frying: oil or fat can overheat very quickly, particularly on a high setting.**
- Start cooking on a high setting. When food comes to the boil, reduce the setting and maintain a steady heat to cook your food thoroughly. Doing this will reduce the cooking time.
- Using a lid will reduce cooking times through retaining the heat.
- Minimise the amount of liquid or fat to reduce cooking times.

Cookware

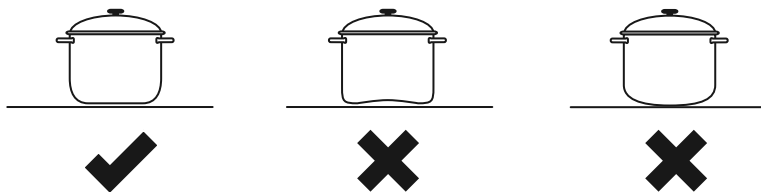

- Use saucepans with thick flat bases. Food in a saucepan with an uneven base will take longer to cook.
- Do not let large saucepans or frying pans overlap the bench, as this can deflect heat onto your benchtop and damage its surface.
- Always make sure saucepans are stable. Using very heavy saucepans may bend the pan supports or deflect the flame.
- Make sure the size of the pan matches the size of the burner. A small pot on a large burner is not efficient. The following table shows the minimum and maximum saucepan base diameters that may be used on each burner:

BURNER		MINIMUM DIAMETER	MAXIMUM DIAMETER
Auxiliary		12cm	-
Semi-rapid		12cm	-
Wok	regular pans	18cm	26cm
	woks (with wok stand)	-	45cm

Using a wok

- Use your wok only on a wok burner and with the supplied wok stand.
- Make sure the wok does not push any other pans aside. This could make them unstable, or deflect heat onto nearby walls or the benchtop.

IMPORTANT!

Make sure that the wok stand is stable: its notches need to fit tightly on the grating.

- Note: to purchase additional wok stands, contact Customer Care.

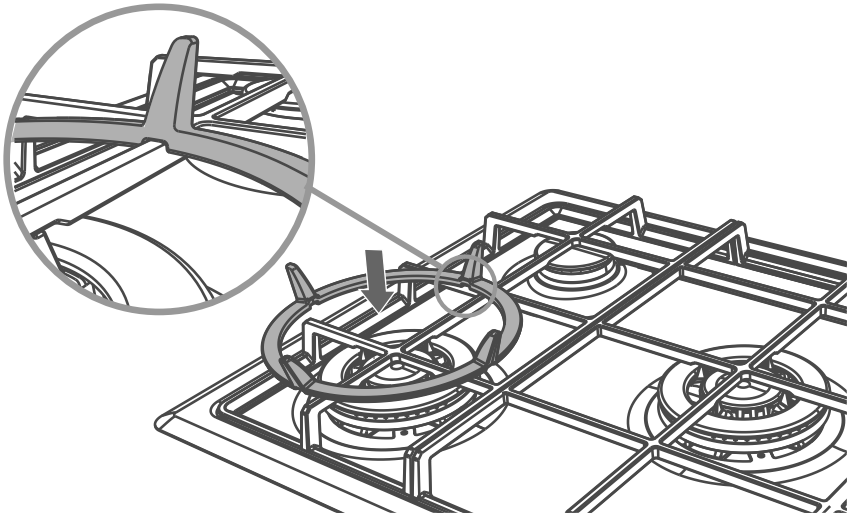

Using the supplied wok stand

CARE AND CLEANING

IMPORTANT!

Before any cleaning or maintenance, always:

- turn all burners off.
- switch the power to the cooktop off at the wall.
- make sure that the cooktop and its parts are a safe temperature to touch.

General advice

- Clean the cooktop regularly—do not let stains become burnt on, as they may become very difficult to remove.
- Do not use abrasive cleaners, cloths or pads to clean any part of your cooktop. Some nylon scourers may also scratch. Check the label.
- Clean up spillages as soon as possible. If left to dry on, food residue may clog the flame ports, causing an uneven flame pattern.
- Make sure that no cleaner residue is left on any cooktop part; when heated, these could stain the cooktop.
- See the following pages for instructions on replacing the pan supports and reassembling the burners correctly after cleaning.
- Do not clean cooktop parts in a self-cleaning oven.
- Do not use a steam cleaner.

WHAT? HOW OFTEN?	HOW?	IMPORTANT!
Stainless steel base After every use	<ol style="list-style-type: none">① Soak any stubborn stains under a hot soapy cloth.② Wipe the soiling off with a cloth using a mild household detergent or stainless steel cleaner.③ Wipe with a clean damp cloth.④ Wipe the surface dry with a microfibre cloth.⑤ For extra shine, use a suitable stainless steel polish. <ul style="list-style-type: none">• Hard water spots can be removed with household white vinegar.	<ul style="list-style-type: none">• Do not use abrasive cleaners, steel soap pads or sharp objects on stainless steel.• Always read the label to make sure that your stainless steel cleaner does not contain chlorine compounds as these are corrosive and may damage the appearance of your cooktop.• Always rub the stainless steel in the direction of the grain.• The graphics are etched onto the steel by laser and will not rub off.
Control dials As needed	<ol style="list-style-type: none">① Wipe with a damp cloth and mild detergent. Stainless steel cleaner can be used on the top surface of the dials only.② Dry thoroughly with a soft cloth.	<p>Do not use oven cleaner on the dials, as doing so may damage their coating.</p>

CARE AND CLEANING

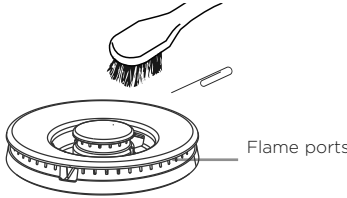
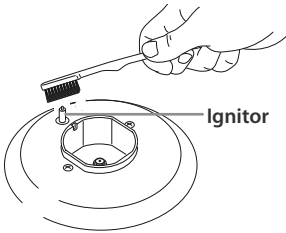
WHAT? HOW OFTEN?	HOW?	IMPORTANT!
<p>Burner caps and rings, flame spreaders, pan supports, wok stand</p> <p>As needed, but at least once a month</p>	<ol style="list-style-type: none"> ① Remove the parts that you wish to clean. See the the illustrations following this chart. ② Soak stubborn stains in a solution of biological clothes washing detergent or powdered dishwasher detergent. ③ Clean the parts in hot soapy water. Use a stiff nylon brush or straight-ended paper clip to clear the flame ports.  <ol style="list-style-type: none"> ④ Rinse in warm water. ⑤ Dry thoroughly. ⑥ Replace the parts correctly, as shown in the drawings following this chart. 	<ul style="list-style-type: none"> • Make sure you keep the flame ports clear. Soiling from food spillage may clog these and cause ignition problems or uneven flame patterns. • Remove stains left by food or spillovers as soon as possible. If left to burn on, they may be difficult to remove or even permanently discolor these parts. • Before replacing the burner parts, make sure that they are completely dry. Wet burner parts may result in an irregular flame. • Before lighting a burner you have reassembled, check that all of its parts have been positioned correctly. Incorrect assembly can cause dangerous irregular flames and ignition problems.
<p>Ignitor</p> <p>At least once a month</p>	<p>Clean these very carefully using a toothbrush dipped into denatured alcohol.</p> 	<p>A clean ignitor ensures trouble-free sparking. Check the ignitor regularly to make sure it is clean.</p>
<p>All gas components of the cooktop</p> <p>Once every 3-4 years</p>	<ul style="list-style-type: none"> • Contact your local Authorised Repairer to perform a thorough check on all gas components of the cooktop. • For Authorised Repairer details, see your Service & warranty book or contact Customer Care. 	<ul style="list-style-type: none"> • All checking and maintenance must be performed by a suitably qualified person. • If the gas is connected with a flexible hose, checking should include inspecting the entire length of the flexible hose assembly for any sign of wear or damage.

CARE AND CLEANING

Replacing the pan supports correctly

CG905C models

The wok support goes in the centre, over the wok burner. The other two pan supports are interchangeable, but need to be rotated to match the rounded corners of the cooktop base.

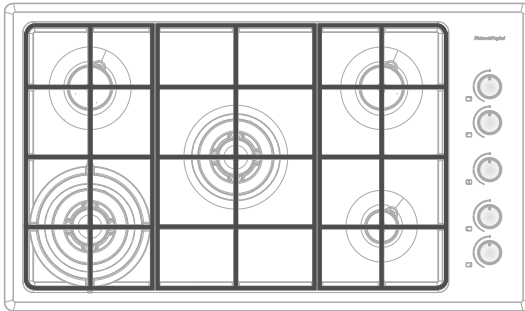
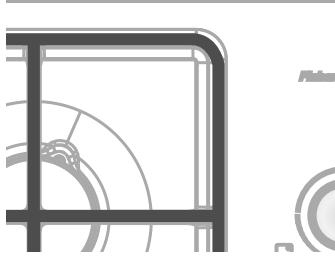

Correct positioning of pan supports (CG905C models)

CG604C models

The pan supports are interchangeable, but they can only be placed as shown and need to be rotated to match the rounded corners of the cooktop base.

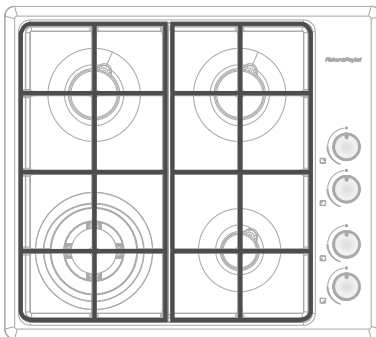

Correct positioning of pan supports (CG604C models)

CARE AND CLEANING

Replacing the burner parts correctly

Semi-rapid and auxiliary burners

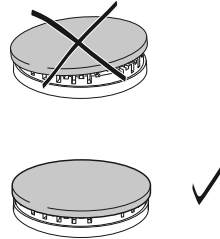
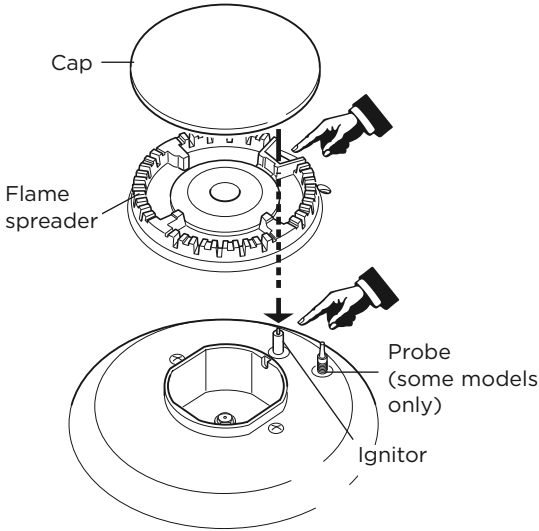

Correct positioning of semi-rapid, rapid, and auxiliary burner parts

Wok burner with cast iron cap and ring

Fit the flame spreader to the housing as shown by the arrow following. Make sure the burner is not able to rotate.

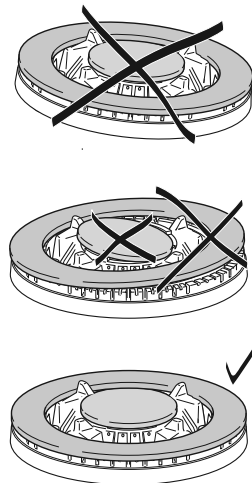
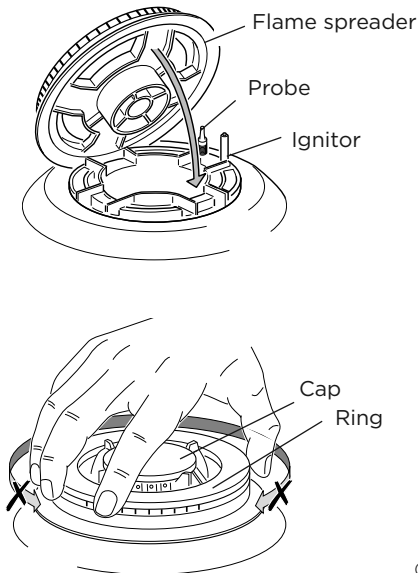

Correct positioning of cast iron wok burner parts

TROUBLESHOOTING

PROBLEM	POSSIBLE CAUSES AND SOLUTIONS
There is a strong gas smell.	<p>The gas connection could be leaking because of incorrect installation or damaged piping</p> <p>IMPORTANT! Do not use any electrical equipment or operate any electrical switches.</p> <ol style="list-style-type: none">① If any burners are on, turn all of them off immediately.② If you know how to shut off the gas supply to your cooktop (either at the valve or the gas bottle), do so.③ Open a window to let the gas out.④ Contact your local Authorized Repairer as soon as possible. <p>IMPORTANT! Do not use the cooktop until it has been repaired.</p>
There is a slight rubbery or metallic smell when I use the cooktop for the first time.	<p>This is normal for first use and is caused by manufacturing residues burning off. The smell will disappear with use.</p>
There is a power failure.	<p>You can still use your cooktop, but will need to match-light the burner(s). To do so, press down and turn the dial counter-clockwise to High while holding a lighted match close to the side of the burner. Wait until the flame is burning evenly before adjusting it.</p>
There is no clicking/sparking.	<p>There is a power failure. See entry 'There is a power failure' above.</p>
There is clicking/sparking, but a burner or burners won't light easily or at all.	<p>The ignitor(s) may be dirty or wet. Clean them following the instructions in 'Care and cleaning'.</p> <p>Wait 1 minute, then try to relighting the burner again, holding the dial for a few more seconds this time around. If this doesn't work and the burner still won't light, see the other possible causes and solutions below.</p> <p>The gas supply may not be turned on at the valve or gas bottle. Turn all the burners off, and check whether the gas supply to the cooktop is turned on.</p> <p>The gas supply to the house may not be working. You should hear the gas when you turn a burner on.</p> <p>If you use bottled gas, this may indicate you are getting near the end of the bottle and need to replace it.</p> <p>Burner parts may be clogged or wet. Make sure that they are clean and dry. See 'Care and cleaning' for instructions.</p> <p>Burner parts may not have been replaced correctly. Check the assembly and make sure the burner cap is sitting flat. See 'Care and cleaning' for illustrations.</p>

TROUBLESHOOTING

PROBLEM	POSSIBLE CAUSES AND SOLUTIONS
The flame has been blown out by a draft or extinguished by a spill.	The flame failure protection will automatically cut the gas supply to the burner off. Turn the corresponding dial to O (OFF), then wait for at least 1 minute before attempting to relight. This is to allow for any small amount of gas that may have escaped to disperse.
The flame goes out at low settings.	The gas supply pressure may be low. Check this with your service person or installer. If you use bottled gas, this may indicate you are getting near the end of the bottle
The flames are yellow or yellow-tipped rather than blue.	Burner parts (especially the flame ports) may be clogged or wet. Check that they are clean and dry. The cooktop may have been connected to the wrong type of gas or the gas pressure is not correct. Contact Customer Care and do not use your cooktop until it has been checked by a qualified technician.
The flame pattern is uneven around the burner.	Burner parts (especially the flame ports) may be clogged or wet. Check that they are clean and dry. See 'Care and cleaning' for instructions and illustrations on clearing clogged flame ports. After cleaning, check that there is flame coming out of each port.

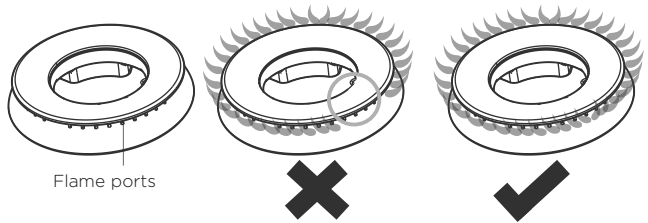

Burner parts may not have been replaced correctly. Check the assembly and make sure the burner cap and/or ring is sitting flat on the flame spreader. See 'Care and cleaning' for illustrations.

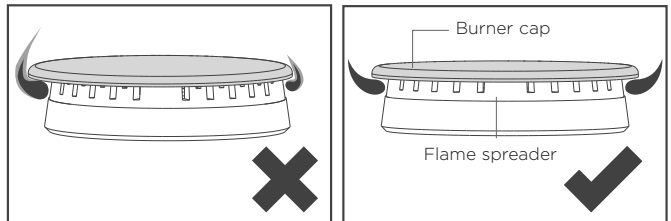

WARRANTY AND SERVICE

Before you call for service or assistance ...

Check the things you can do yourself. Refer to the installation instructions and your user guide and check that:

- ① Your product is correctly installed.
- ② You are familiar with its normal operation.

If after checking these points you still need assistance or parts, please refer to the Service & Warranty book for warranty details and your nearest Authorised Service Centre, Customer Care, or contact us through our website www.fisherpaykel.com.

This cooktop has been designed and constructed in accordance with the following codes and specifications:

In New Zealand and Australia:

AGA101 (AS 4551)	Approval Requirements for Domestic Gas cooking appliances
AS/NZS 60335-1	General Requirements for Domestic electrical appliances
AS/NZS 60335-2-6	Particular Requirements for Domestic electrical cooking appliances
AS/NZS 1044	Electromagnetic Compatibility Requirements

Complete and keep for safe reference:

Model _____
Serial No. _____
Purchase Date _____
Purchaser _____
Dealer _____
Suburb _____
Town _____
Country _____

FISHERPAYKEL.COM

© Fisher & Paykel Appliances 2019. All rights reserved.

The product specifications in this document apply to the specific products and models described at the date of issue. Under our policy of continuous product improvement, these specifications may change at any time. You should therefore check with your Dealer to ensure this document correctly describes the product currently available.

NZ AU

591314D 10.19