

Instruction Manual EN
Microwave

Gebrauchsanweisung DE
Mikrowelle

Manual de Uso ES
Microonda

Manual de Utilização PT
Microondas



EN

Dear Customer,

Thank you for choosing this **SMEG** product.

We ask you to read the instructions in this booklet very carefully as this will allow you to get the best results from using it.

KEEP THE DOCUMENTATION OF THIS PRODUCT FOR FUTURE REFERENCE.

Always keep the instruction manual handy. If you lend the appliance to someone else give them the manual as well!

The user manual is also available for download at www.smeg.com

DE

Sehr geehrter Kunde,

Danke dass Sie sich für dieses **SMEG** Gerät entschieden haben.

Wir bitten Sie, die in diesem Heft enthaltenen Anweisungen aufmerksam durchzulesen, die helfen Ihnen, bei der Nutzung Ihres Gerätes die besten Ergebnisse zu erzielen.

BEWAHREN SIE DIE DOKUMENTATION DIESES GERÄTES AUF, UM KÜNFTIG IN IHR NACHSCHLAGEN ZU KÖNNEN.

Halten Sie die Gebrauchsanleitung immer griffbereit. Falls Sie das Gerät Dritten überlassen, stellen Sie ihnen auch die entsprechende Betriebsanleitung zur Verfügung!

Die Gebrauchsanweisung ist auch auf unserer Homepage verfügbar www.smeg.com

ES

Estimado Cliente,

Gracias por haber elegido este producto **SMEG**.

Solicitamos una lectura atenta de las instrucciones que constan en este libro, que le permitirán obtener un mejor resultado en la utilización del producto.

CONSERVE LA DOCUMENTACIÓN DE ESTE PRODUCTO PARA CONSULTAS FUTURAS.

Tenga el manual de instrucciones siempre a mano. ¡Si cede el aparato a terceros, entrégueles también el correspondiente manual!

El manual del usuario también está disponible para su descarga en www.smeg.com

PT

Prezado cliente,

Obrigado por escolher este produto **SMEG**.

Pedimos-lhe que leia atentamente as instruções deste manual, pois isto permitir-lhe-á obter os melhores resultados com o seu aparelho.

GUARDE A DOCUMENTAÇÃO DESTE APARELHO PARA CONSULTAS FUTURAS.

Mantenha este manual sempre à mão. Caso ceda o aparelho a terceiros, entregue-lhes também as respetivas instruções!

Este manual de instruções também se encontra disponível em www.smeg.com

Contents

1. Instructions	4
1.1. Safety Information	4
1.2. Disposal	9
1.3. This user manual	9
1.4. How to read the user manual	9
2. Description	10
2.1. General Description	10
2.2. Control Panel	11
2.3. Accessories	11
2.4. Description of functions	12
3. Use	13
3.1. Advantages of the microwave oven	13
3.2. Instructions	14
3.3. What type of containers may be used?	14
3.4. First use	16
3.5. Using the oven	16
3.6. Cooking Functions	17
3.7. Special functions and automatic programs	18
3.8. During Operation	22
4. Cleaning and Maintenance	23
4.1. Instructions	23
4.2. Cleaning the surfaces	23
4.3. Ordinary daily cleaning	23
4.4. Food stains and residues	23
4.5. Cleaning the appliance	23
4.6. Troubleshooting	24
5. Installation	25
5.1. Technical Features	25
5.2. Installation Instructions	25
6. Installation Images	95



Instructions

1.1. Safety Information

Before the installation and use of the appliance, carefully read the supplied instructions. The manufacturer is not responsible if an incorrect installation and use causes injuries and damages. Always keep the instructions with the appliance for future reference.

CHILDREN AND VULNERABLE PEOPLE SAFETY

Warning! Risk of suffocation, injury or permanent disability.

- This appliance can be used by children aged from 8 years and above and persons with reduced physical, sensory or mental capabilities or lack of experience and knowledge if they are supervised by an adult or a person who is responsible for their safety.
- Do not let children play with the appliance.
- Keep all packaging away from children.
- **WARNING:** Keep children away from the appliance when it operates or when it cools down. Accessible parts are hot.
- If the appliance has a child safety device, we recommend that you activate it. Children under 3 years must not be left unsupervised in the vicinity of the appliance.
- Cleaning and user maintenance shall not be made by children without supervision.

GENERAL SAFETY

- This appliance is intended to be used in household and similar applications such as:
 - staff kitchen areas in shops, offices and other working environments;
 - farm houses;
 - by clients in hotels, motels and other residential environments;
 - bed and breakfast type environments.
- Internally the appliance becomes hot when in operation. Do not touch the heating elements that are in the appliance. Always use oven gloves to remove or put in accessories or ovenware.
- **WARNING:** Do not heat liquids and other foods in sealed containers. They are liable to explode.



- Only use utensils that are suitable for use in microwave ovens.
- When heating food in plastic or paper containers, keep an eye on the appliance due to the possibility of ignition.
- The appliance is intended for heating food and beverages. Drying of food or clothing and heating of warming pads, slippers, sponges, damp cloth and similar may lead to risk of injury, ignition or fire.
- **Warning!** The oven cannot be used if:
 - The door is not closed correctly;
 - The door hinges are damaged;
 - The surfaces of the contact between the door and the oven front are damaged;
 - The door window glass is damaged;
 - There is frequent electrical arcing inside the oven even though there is no metal object inside.
- The oven can only be used again after it has been repaired by a Technical Assistance Service technician.
- If smoke is emitted, switch off or unplug the appliance and keep the door closed in order to stifle any flames.
- Microwave heating of beverages can result in delayed eruptive boiling. Care must be taken when handling the container.
- The contents of feeding bottles and baby food jars shall be stirred or shaken and the temperature checked before consumption, in order to avoid burns.
- Eggs in their shell and whole hard-boiled eggs should not be heated in the appliance since they may explode, even after microwave heating has ended.
- **Warning!** Do not heat pure alcohol or alcoholic drinks in the microwave. **FIRE RISK!**
- **Beware!** To avoid food overheating or burning it is very important not to select long time periods or power levels that are too high when heating small quantities of food. For example, a bread roll can burn after 3 minutes if the power selected is too high.



Instructions

- For toasting, use just the grilling function and watch the oven all the time. If you use a combined function to toast bread it will catch fire in a very short time.
- Make sure you never catch the power cables of other electrical appliances in the hot door or the oven. The cable insulation may melt. **Danger of short-circuiting!**



- **Take care when heating liquids!**

When liquids (water, coffee, tea, milk, etc.) are nearly at boiling point inside the oven and are taken out suddenly, they may spurt out of their containers.

DANGER OF INJURIES AND BURNS!

To avoid that type of situation when heating liquids, put a teaspoon or glass rod inside the container.

INSTALLATION

- The electric system must be equipped with a means for disconnection, with a contact separation in all poles that provides full disconnection under overvoltage category III.
- If a plug is used for the electric connection, then it must be accessible after installation.
- Protection against electric shock must be provided by the electrical installation
- Warning: The oven must be earthed.

CLEANING

- The appliance should be cleaned regularly and any food deposits removed.
- Do not use a steam cleaner to clean the appliance.
- Failure to maintain the appliance in a clean condition could lead to deterioration of the surface that could adversely affect the life of the appliance and possibly result in a hazardous situation.



- Do not use harsh abrasive cleaners or sharp metal scrapers to clean the glass door since they can scratch the surface, which may result in shattering of the glass.
- The door contact surfaces (the front of the cavity and the inside part of the doors) must be kept very clean in order to ensure the oven functions correctly.
- Please follow the instructions regarding cleaning in the section "Oven Cleaning and Maintenance".

REPAIRS

- **WARNING:** Before maintenance cut the power supply.
- **WARNING:** Only a competent person can carry out any service or repair operation that involves the removal of a cover which gives protection against exposure to microwave energy.
- **WARNING:** If the door or door seals are damaged, the appliance must not be operated until it has been repaired by a competent person.
- If the power cable is damaged it should be substituted by the manufacturer, authorized agents or technicians qualified for this task in order to avoid dangerous situations. Furthermore, special tools are required for this task.
- Repair and maintenance work, especially of current carrying parts, can only be carried out by technicians authorized by the manufacturer.

Avoid damaging the oven or other dangerous situations by following these instructions:

- Do not switch on the oven without the turntable support, the turntable ring and the respective plate being in place.
- Never switch on the microwave when it is empty. If there is no food inside there may be an electrical overcharge and the oven could be damaged. **RISK OF DAMAGE!**
- For carrying out oven programming tests put a glass of water inside the oven. The water will absorb the microwaves and the oven will not be damaged.



Instructions

- Do not cover or obstruct the ventilation openings.
- Use only dishes suitable for microwaves. Before using dishes and containers in the microwave, check that these are suitable (see the section on types of dishes).
- Never remove the mica cover on the ceiling of the oven interior! This cover stops fat and pieces of food damaging the microwave generator.
- Do not keep any inflammable object inside the oven as it may burn if the oven is switched on.
- Do not use the oven as a pantry.
- Do not use the oven for frying as it is impossible to control the temperature of oil heated by microwaves.
- The turntable and the grills can bear a maximum load of 8 kg. To avoid damaging the oven, do not exceed this load.



1.2. Disposal

Eliminating the packaging



The packaging carries the Green Dot. Use the right bins when discarding all of the packaging materials, such as the cardboard, styrene and plastic films. This will ensure that the packaging materials are recycled.

Disposal of old electrical appliances



The European Directive 2012/19/EU on Waste Electrical and Electronic Equipment (WEEE), requires that old household electrical appliances must not be disposed of in the normal unsorted municipal waste stream. Old appliances must be collected separately in order to optimise the recovery and recycling of the materials they contain and reduce the impact on human health and the environment.

The crossed out “wheeled bin” symbol on the product reminds you of your obligation, that when you dispose of the appliance it must be separately collected.

Consumers should contact their local authority or retailer for information concerning the correct disposal of their old appliance.

Before you dispose of your appliance, remove the power cable, cut it and dispose of it.

1.3. This user manual

This user manual is an integral part of the appliance and must therefore be kept in its entirety and within the user's reach for the whole working life of the appliance.

- Read this user manual carefully before using the appliance.

1.4. How to read the user manual

This user manual uses the following reading conventions:



Instructions

General Information on this user manual, on safety and final disposal.



Description

Description of the appliance and its accessories.



Use

Information on the use of the appliance and its accessories, cooking advice.



Cleaning and Maintenance

Information for proper cleaning and maintenance of the appliance.



Installation

Information for the qualified technician: Installation, operation and inspection.



Safety Instructions



Information



Advice



Description

2.1. General Description

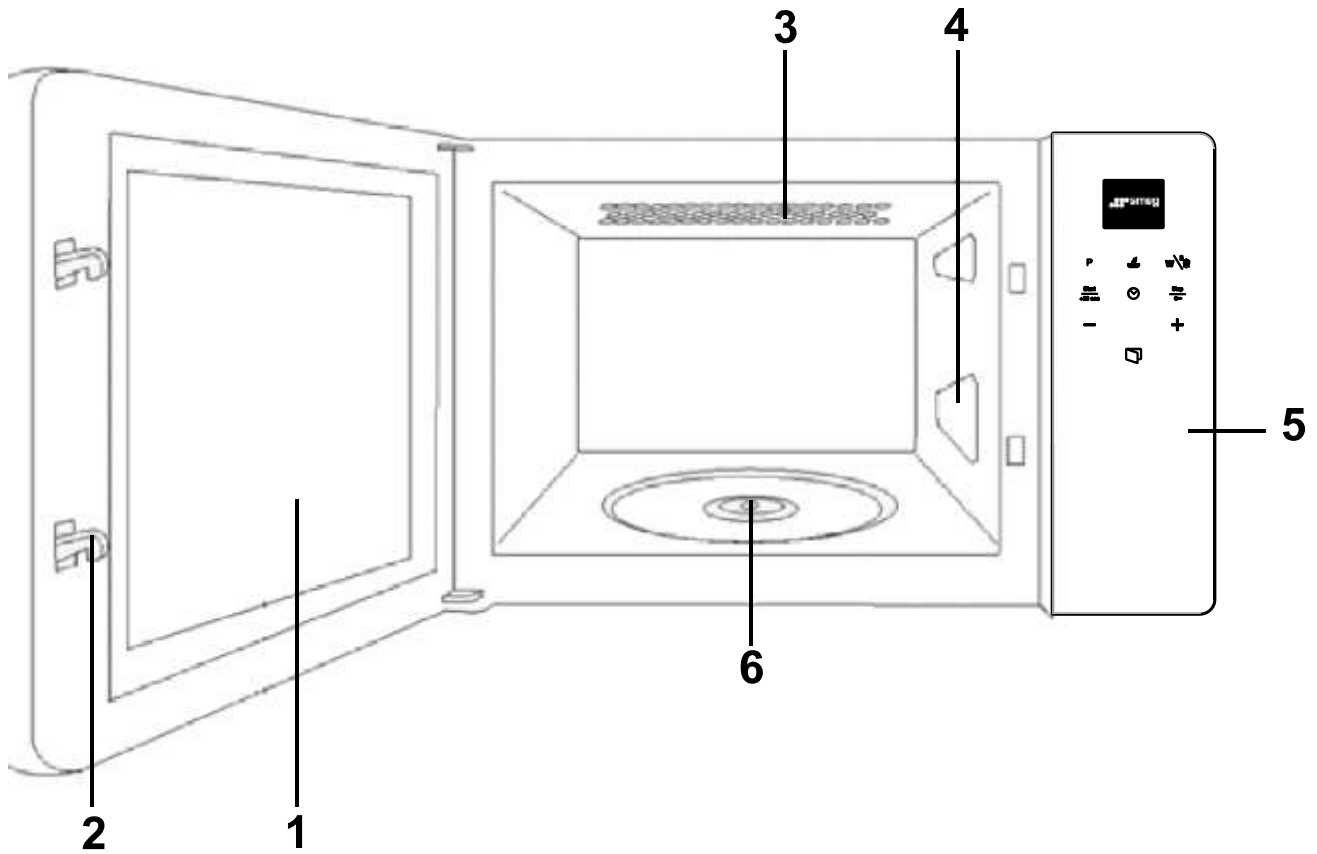

1. Glass window on the door
2. Catch
3. Quartz grill
4. Mica covers
5. Control panel
6. Slot for rotating base



2.2. Control Panel

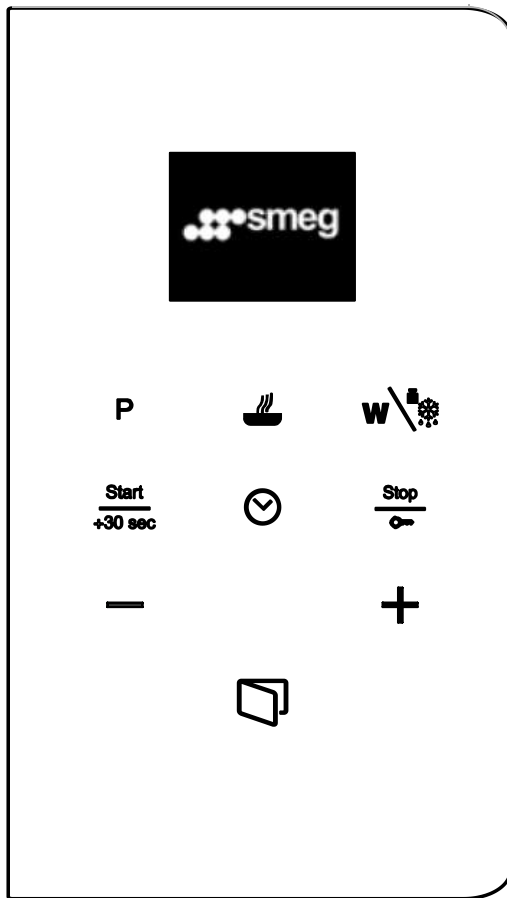

1		Display
2	P	Program key
3		Duration key
4	W /	Power / Weight key
5	<u>Start</u> +30sec	Start key
6		Clock key
7	<u>Stop</u> 	Stop / Safety block key
8	-	Minus key
9	+	Plus key
10		Door open key

2.3. Accessories

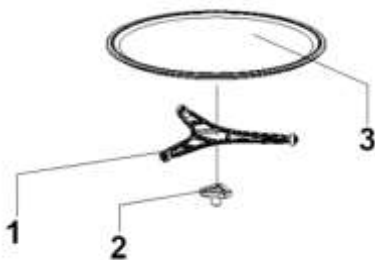

1. Rotating base
2. Turntable support
3. Rotating plate

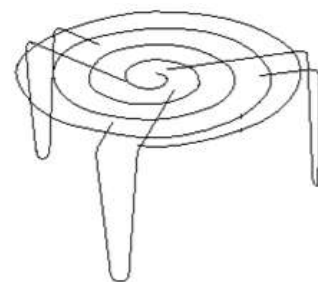

Grill



Some models are not provided with all accessories.



Description

2.4. Description of functions

Symbol	Description	Power	Foods
	Microwave	P 01 -----160W	Slow defrosting for delicate foods, keeping food hot
		P 02 -----320W	Cooking at low heat, boiling rice Fast defrosting
		P 03 -----480W	Melting butter Heating baby food
		P 04 -----640W	Cooking vegetables and other foods Cooking and heating carefully, Heating and cooking small quantities Heating delicate foods
		P 05 -----700W	Cooking and heating liquids and other foods fast
	Microwave + Grill	P 01 -----95W	Browning toast
		P 02 -----135W	Grilling poultry and meat
		P 03 -----170W	Cooking meatloaves and "au gratin" dishes
		P 04 -----200W	Preparing meat round
		P 05 -----230W	Potatoes "au gratin"
	Grill	---	Grill all sorts of foods
	Defrosting	---	Defrosting by time.

AUTO - 1	Automatic cooking	---	Boiling potatoes.
AUTO - 2		---	Fritters and stews
AUTO - 3		---	Mashed potatoes



3.1. Advantages of the microwave oven

In a conventional cooker, the heat that is radiated through the resistances or gas burners slowly penetrates the foods from the outside in. Therefore, there is a great loss of energy in heating the air, the oven components and the containers holding the food.

In the microwave, the heat is generated by the foods themselves, i.e. the heat goes from the inside out. There is no loss of heat to the air, the walls of the cavity or the containers (as long as they are microwave-safe containers). This means that only the food is heated.

To sum up, microwave ovens have the following advantages:

1. Savings in cooking time; in general, there is a $\frac{3}{4}$ reduction in time compared to conventional cooking.
2. Ultra fast defrosting of foods, thus reducing the danger of bacteria developing.
3. Energy-saving.
4. Conservation of the nutritional value of foods due to the reduction in cooking time.
5. Easy cleaning.

Microwave oven operating mode

The microwave oven contains a high voltage valve called a Magnetron, which converts the electrical energy into microwave energy. These electromagnetic waves are channelled towards the inside of the oven by a wave guide and distributed using a metallic disperser or a rotating plate.

Inside the oven, the microwaves are propagated in all directions and reflected by the metallic walls, thus uniformly penetrating the foods.

Why the food is heated

Most foods contain water and the water molecules vibrate with the microwaves.

The friction between the molecules generates heat, which raises the temperature of the foods, defrosting or cooking them or keeping them hot.

Because heat is formed inside the foods:

- The foods may be cooked without any liquids or oils, or with very little of these;
- Defrosting, heating or cooking in the microwave oven is faster than in a conventional oven;
- The vitamins, minerals and nutritious substances are conserved;
- Neither the natural colour nor the aroma are altered.

The microwaves go through porcelain, glass, cardboard or plastic, but not through metal. For this reason, metallic containers or containers with metallic parts should not be used in the microwave oven.

Microwaves are reflected by metal...

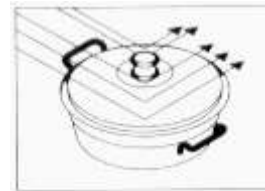

... they go through glass and porcelain...

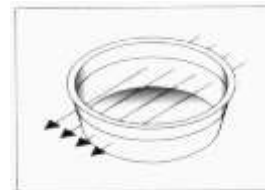

... and are absorbed by the foods.

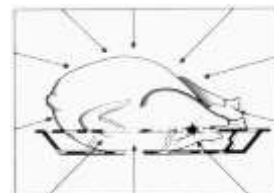



3.2. Instructions



High temperature inside the oven during use

Danger of fire or explosion

- Do not spray any products near the oven.
- Do not use or leave flammable materials near the oven.
- Do not use plastic kitchenware to cook food (except with the microwave function).
- Do not put sealed tins or containers in the oven.
- Do not leave the oven unattended during cooking operations where fats or oils could be released.
- Remove all trays and racks which are not required during cooking

3.3. What type of containers may be used?

Microwave function

In the microwave function, it is important to remember that the microwaves are reflected by metallic surfaces. Glass, porcelain, ceramic, plastic and paper will allow the microwaves to pass through.

Therefore, **metallic pans and dishes for cooking or containers with metallic components or decorations may not be used in the microwave.** Glassware and ceramic with **metallic decorations or parts** (e.g. lead glass) may not be used.

The **ideal** materials to be used for cooking in a microwave oven are refractory, heat-resistant glass, porcelain or ceramic. Very fine crystal and porcelain should only be used for a short time, to defrost or reheat foods that have already been cooked.

Test the dishes

Place the dish inside the oven at the maximum power level for 20 seconds. If it is cold or not very hot, it is suitable. However, if it gets very hot or causes an electrical arch, it is not suitable.

Hot foods transmit heat to the dish, which may become very hot. Therefore, always use a **glove!**

Grill function

In the case of the grill function, the dish must be resistant to temperatures of at least 250°C.

Plastic dishes are not suitable.

Combined function

In the combined function, the dishes that are used must be suitable for both microwave and grill cooking.

Aluminium containers and foils

Precooked foods in aluminium containers or wrapped in aluminium foil may be placed in the microwave oven if the following instructions are followed:

- Pay attention to the manufacturer's instructions that are printed on the packaging,
- Aluminium containers should not be higher than 3 cm and they should not come into contact with the walls of the cavity (minimum distance 3 cm). The aluminium lid should be removed.
- Place the aluminium container directly on the rotating plate. If the grille is used, the container should be placed on a porcelain plate. Never put the container directly on the grille!
- The cooking time will be longer because the microwaves only enter the food from above. In case of doubt, only use microwave-safe dishes.
- Aluminium foil may be used to reflect the microwaves during the defrosting process. Delicate foods, such as poultry or minced meat, may be protected from excessive heat by covering the respective ends.
- **Important:** the aluminium foil must not come into contact with the walls of the cavity, as this could cause an electrical arch.



Lids

The use of glass or plastic lids or adherent film is recommended, for the following reasons:

1. They prevent excessive evaporation (especially in very long cooking periods);
2. The cooking process is faster;
3. The food does not go dry;
4. The aroma is preserved.

The lid should have holes to avoid any type of pressure from building up. Plastic bags should also have openings. Baby bottles and baby food jars and other similar containers must only be heated without the lid, as they might explode if it is left on.

The following table gives general guidelines on the type of dishes that are suitable for each situation.

Table – dishware

Operating mode Type of dish	Microwave		Grill	Microwave + Grill
	Defrost / heat	Cook		
Glass and porcelain 1) Domestic, non fire-resistant, may be washed in dishwasher	yes	yes	no	no
Glazed ceramic Fire-resistant glass and porcelain	yes	yes	yes	yes
Ceramic, earthenware dishes unglazed glazed without metallic decorations	yes	yes	no	no
Earthenware dishes glazed	yes	yes	no	no
unglazed	no	no	no	no
Plastic dishes 2) heat-resistant up to 100°C	yes	no	no	no
heat-resistant up to 250°C	yes	yes	no	no
Plastic films 3) Cling film	no	no	no	no
Cellophane	yes	yes	no	no
Paper, cardboard, parchment 4)	yes	no	no	no
Metal Aluminium foil	yes	no	yes	no
Aluminium containers 5)	no	yes	yes	yes
Accessories	yes	yes	yes	yes

1. No golden or silver edges and no lead glass.
2. Remember the manufacturer's tips!
3. Do not use metal clips to close the bags. Perforate the bags. Use films only to cover foods.

4. Do not use paper plates.

5. Only shallow aluminium containers without lids. The aluminium must not come into contact with the walls of the cavity.



Use

3.4. First use

1. Remove any protective film from the outside or inside of the appliance, including accessories.
2. Remove any labels (apart from the rating plate) from the accessories and from the oven cavity.
3. Remove and wash all the appliance accessories (see 4 Cleaning and Maintenance).
4. Heat the empty oven at maximum temperature (using traditional functions) so as to remove any manufacturing residues.



For the first heating use a traditional function and not a microwave function.

3.5. Using the oven

Operating modes

Stand-by: When no function is selected, the display shows the current time.

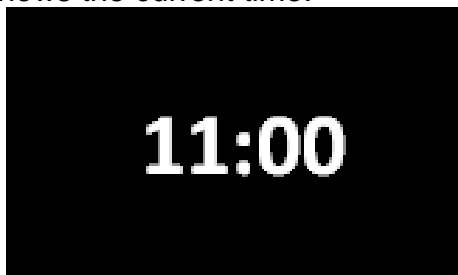

ON: When any function starts the display shows the current settings such as the current time, the duration and the microwave power.



Setting the time

On the first use, or after a power failure **0:00** will be flashing on the appliance's display. To be able to start any cooking function, the current time must be set.

1. Press the **CLOCK** key (6) until the hour numbers start to flash.
2. Enter the time value by pressing “-” or “+” keys (8/9).
3. Press the **CLOCK** key (6) again to set the minutes.
4. Enter the minute's value by pressing “-” or “+” keys (8/9).
5. To finish, press the **CLOCK** key (6) again.



It is not possible to change the time if the oven is **ON**.

Safety Block

It is possible to block functioning of the appliance (for example, to prevent it being used by children); to do so:

1. Press the **STOP / SAFETY BLOCK KEY** (7) for 3 seconds. The microwave will beep and the appliance will be locked. The screen will display four lines and oven operation will be blocked.
2. The Clock will continue to be displayed and the Safety block indicator will illuminate on the **DISPLAY** (1).
3. In order to unlock the microwave, press the **STOP / SAFETY BLOCK KEY** (7) for 3 seconds. The microwave will beep and the screen will display the clock again.

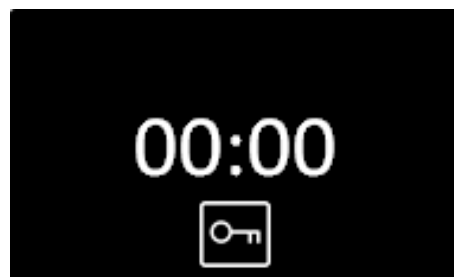



3.6. Cooking Functions

Microwave



1. Press the **PROGRAM KEY «P»** (2). The **MICROWAVE** indicator  lights up on the **DISPLAY** (1).
2. Confirm the function by pressing the **PROGRAM KEY «P»** (2) again.
3. Press the **DURATION KEY** (3).
4. Enter the desired operating time pressing “-” or “+” keys (8/9).
5. Confirm by pressing the **DURATION KEY** (3) again.
6. To change the power of the microwave, press the **POWER/ WEIGHT KEY** (4). (If this key is not pressed, the appliance functions at the maximum power.)
7. Enter the desired power pressing “-” or “+” keys (8/9).
8. Confirm by pressing the **POWER/ WEIGHT KEY** (4) again.
9. Press the **START KEY** (5). The microwave starts to function.



If the door is opened then cooking will stop. Once the door is closed press the **START** key to resume cooking.

QUICK START microwave function



The **QUICK START** function allows the microwave to be started quickly. This is useful for heating small quantities of liquid or food.

1. In the Standby mode press **START** (5). The appliance starts immediately to function on the **MICROWAVE** function at the maximum power for 30 seconds.
2. If you would like to increase the functioning time press the **START** key (5) again. Each time the

START key (5) is pressed the duration increases in 30 seconds.

Combination



Combination cooking is a mix of traditional cooking and microwave operation.

Microwave + Grill



The use of the grill results in perfect browning of the food's surface. Using the microwave on the other hand leads to a rapid internal cooking of the food.

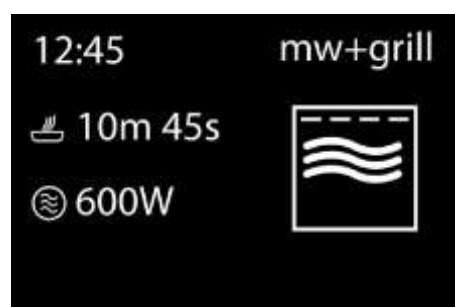

1. Press the **PROGRAM KEY «P»** (2).
2. Select the **MICROWAVE + GRILL** function  by pressing “-” or “+” keys (8/9).
3. Confirm the function by pressing the **PROGRAM KEY «P»** (2) again.
4. Press the **DURATION KEY** (3).
5. Enter the desired operating time by pressing “-” or “+” keys (8/9).
6. Confirm by pressing the **DURATION KEY** (3) again.
7. To change the power of the microwave, press the **POWER/ WEIGHT KEY** (4). (If this key is not pressed, the appliance functions at the maximum power.)
8. Enter the desired power by pressing “-” or “+” keys (8/9).
9. Confirm by pressing the **POWER/ WEIGHT KEY** (4) again.
10. Press the **START KEY** (5). The microwave starts to function.



Improper user

Risk of damages to the appliance

- Do not use the combined functions to heat or boil liquids.



Use

Traditional cooking functions

Grill



The heat coming from the grill element gives perfect grilling results above all for thin and medium thickness meat and allows you to give the food an even browning at the end of the cooking. Perfect for sausages, spare ribs and bacon.

This function enables large quantities of food, particularly meat, to be grilled evenly.



1. Press the **PROGRAM KEY «P»** (2).
2. Select the **GRILL** function  by pressing “-” or “+” keys (8/9).
3. Confirm the function by pressing the **PROGRAM KEY «P»** (2) again.
4. Press the **DURATION KEY** (3).
5. Enter the desired operating time by pressing “-” or “+” keys (8/9).
6. Confirm by pressing the **DURATION KEY** (3) again.
7. Press the **START KEY** (5). The microwave starts to function.

3.7. Special functions and automatic programs

Defrosting by time (manual)

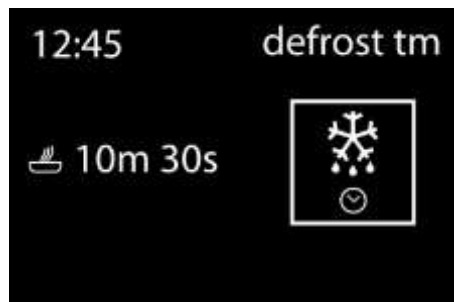

This function allows food to be defrosted by the microwave according to a selected period of time.

1. Press the **PROGRAM KEY «P»** (2).
2. Select the **DEFROSTING BY TIME**  by pressing “-” or “+” keys (8/9).
3. Confirm the function by pressing the **PROGRAM KEY «P»** (2) again.
4. Press the **DURATION KEY** (3).
5. Enter the desired operating time by pressing “-” or “+” keys (8/9).
6. Confirm by pressing the **DURATION KEY** (3) again.
7. Press the **START KEY** (5). The microwave starts to function.
8. When the oven stops and starts to beep, move or turn the foods. To continue, close the door of the microwave and press the start key, to continue the defrosting process.



If the selected defrost duration is more than 5 minutes then, for best results, the dish inside the oven compartment will need to be turned.



Defrosting by weight (automatic)



This function allows food to be microwave defrosted according to the weight and type of food to be defrosted.



1. Press the **PROGRAM KEY «P»** (2).
2. Select the **DEFROSTING BY WEIGHT** function by pressing “-” or “+” keys (8/9). 
3. Confirm the function by pressing the **PROGRAM KEY «P»** (2) again.
4. Program «**PR-01**» flashes (by default).
5. Select the food type (program) by pressing “-” or “+” keys (8/9) (see table below). (If you do not press the “-” or “+” keys «**PR-01**» is selected by default.)
6. Confirm by pressing the **POWER/ WEIGHT KEY** (4).
7. On the display you will see the weight (ex. «**0.1**» by default) and the weight indicator «**kg**».flashing.



8. Indicate the weight of the food (ex. «**1,2 kg** by pressing “-” or “+” keys (8/9).
9. Confirm by pressing the **POWER/ WEIGHT KEY** (4). The program you selected before (ex: «**PR-01**») starts to flash again.



10. Press the **START KEY** (5). The microwave starts to function.
11. Turn the foods around at the moment the microwave beeps and starts to flash on the **DISPLAY** (1): «**TURN**». Close the door again and press the **START** key (5).

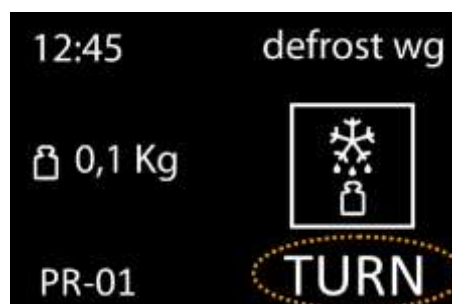

For best results during defrosting the dish inside the oven will need to be turned.

The following table shows the programs for the defrosting by weight function, indicating the weight ranges, defrosting and resting times (to ensure that the food reaches a uniform temperature).

Program	Food	Weight (kg)	Time	Resting time
PR-01	Meat	0,1 – 2,5	03m00s – 1h15m	20 – 30 min
PR-02	Poultry	0,1 – 2,5	03m00s – 1h15m	20 – 30 min
PR-03	Fish	0,1 – 2,5	03m20s – 01h23m	20 – 30 min
PR-04	Fruit	0,1 – 1,0	02m36s – 26m00s	5 – 10 min
PR-05	Bread	0,1 – 1,5	02m25s – 36m15s	5 – 10 min



Use

Special Functions

Auto1: (cook 500g potatoes)

1. Put the potatoes (approx. 500g) with some water in a heat resistant container and place it on the rotating plate in the microwave.
2. Press the **PROGRAM KEY «P»** (2).
3. Select the «**AUTO 1**» function by pressing “-” or “+” keys (8/9).
4. Confirm the function by pressing the **PROGRAM KEY «P»** (2) again.



5. Press the **START** key (5). The microwave starts to function and the screen displays the remaining operating time.

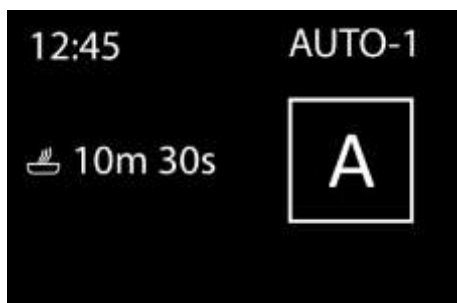

Auto2: (slow boiled / stewed dishes)

1. Place the ingredients to be slow boiled/stewed (e.g. cabbage, chicken stew) in a bowl, cover the bowl and place on the oven's tray.
2. Press the **PROGRAM KEY «P»** (2).
3. Select the «**AUTO 2**» function by pressing “-” or “+” keys (8/9).
4. Confirm the function by pressing the **PROGRAM KEY «P»** (2) again.



5. Press the **START** key (5). The microwave starts to function and the screen displays the remaining operating time.

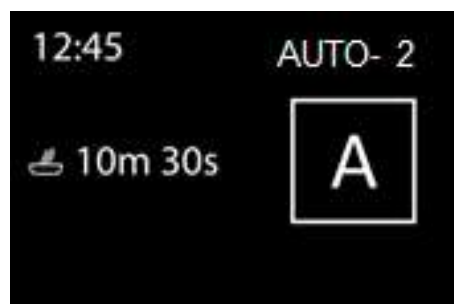

6. Turn the foods around at the moment the microwave beeps and starts to flash on the screen: «**TURN**». Close the door again and press the **START** key (5).

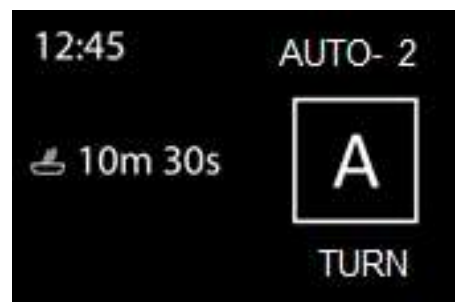



Auto3: (slow boiled / stewed dishes)

1. Prepare the mashed potato using 1 kg of raw potatoes. Place the mashed potato in a suitable container (25-26 cm in diameter) and then place it on the micro-oven tray.
2. Press the **PROGRAM KEY «P»** (2).
3. Select the **«AUTO 3»** function by pressing “-” or “+” keys (8/9).
4. Confirm the function by pressing the **PROGRAM KEY «P»** (2) again.



5. Press the **START** key (5). The microwave starts to function and the screen displays the remaining operating time.

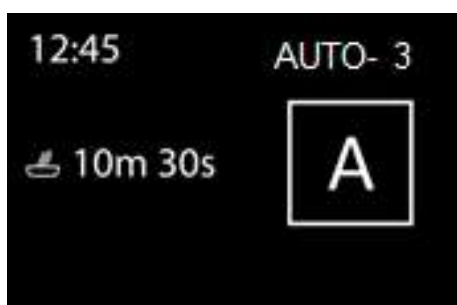

Memory function

The **«MEM»** function allows a range of frequently used parameters (time and power) to be stored in the memory. Nevertheless, you may only use it with the main functions: **Microwave**, **Grill** and **Microwave + Grill**.

Memory storage procedure

1. Press the **PROGRAM KEY «P»** (2).
2. Select the **desired function** (eg. MICROWAVE) by pressing “-” or “+” keys (8/9).
3. Confirm the function by pressing the **PROGRAM KEY «P»** (2) again.

4. Set the desired parameters (duration and power) as described in the basic functions.
5. Press the **PROGRAM KEY «P»** (2) until you hear a beep and the display (1) displays the word **«MEM»**.

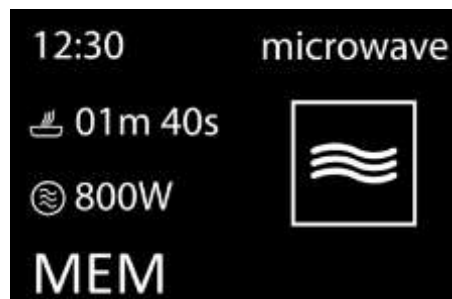

Memory use procedure

1. Press the **PROGRAM KEY «P»** (2). Select the **«MEM»** function by pressing “-” or “+” keys (8/9).
2. Confirm the function by pressing the **PROGRAM KEY «P»** (2) again.
3. Press the **START** key (5). The microwave starts to function.

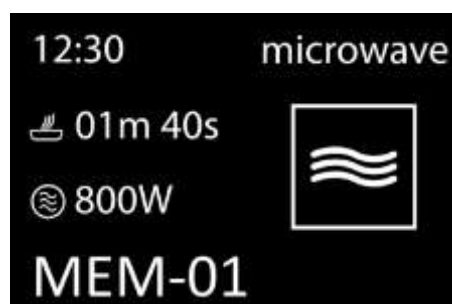

Delete a Memory

1. Press the **PROGRAM KEY «P»** (2).
2. Select the **«MEM»** function by pressing “-” or “+” keys (8/9).
3. Confirm the function by pressing the **PROGRAM KEY «P»** (2) again.
4. Press the **STOP/ SAFETY BLOCK KEY** key (7) until you hear a beep. The oven returns to "Standby" mode.



3.8. During Operation...

During the cooking process, you may open the door at any moment, as:

- THE PRODUCTION OF MICROWAVES IS IMMEDIATELY INTERRUPTED.
- The grill is deactivated and remains at a high temperature.
- The timer stops and the screen shows the operating time that is left.

If you wish, you may:

1. Turn around or move the foods to ensure uniform cooking.
2. Change the power of the microwave, using the “-” and “+” keys.
3. Select another function, using the function keys.

4. Adjust the operating time that is left, by using the “-” or “+” keys.

Close the door again and press the start button. The appliance will start to function again

Function interruption

To interrupt the program, press the **STOP** button or open the door of the appliance.

If you wish to cancel the cooking process, close the door again and press the **STOP** button. The oven will beep and the screen will display the time.

End of program

When the program is finished, the microwave beeps 3 times and the screen displays “**End**”. The beeps are repeated every 30 seconds, until the door is opened or the “**STOP**” button is pressed.



4.1. Instructions



High temperature inside the oven after use

Danger of burns

- Perform cleaning only after letting the appliance cool down.



Improper use

Risk of damage to surfaces

- Do not use a steam jet to clean the appliance.
- Do not use cleaning products containing chlorine, ammonia or bleach on steel parts or parts with metallic finishes on the surface (e.g. anodizing, nickel or chromium-plating).
- Do not use abrasive or corrosive detergents on glass parts (e.g. powder products, stain removers and metallic sponges).
- Do not use rough or abrasive materials or sharp metal scrapers.
- Failure to clean the oven could adversely affect the life of the appliance and pose a hazard.
- Always remove food residues from the oven compartment.



Improper user

Danger of explosion/ burns

- Do not use detergents with high alcohol content or which can release inflammable vapours. Subsequent heating could set off an explosion inside the appliance.



Before cleaning the microwave, ENSURE THAT THE PLUG IS NOT IN THE SOCKET.

4.2. Cleaning the surfaces

To keep the surfaces in a good condition, they should be cleaned regularly after use. Let them cool first.

4.3. Ordinary daily cleaning

Always use only specific products that do not contain abrasive or chlorine-based acids.

Pour the product onto a damp cloth and wipe the surface, rinse thoroughly and dry with a soft cloth or a microfiber cloth.

4.4. Food stains and residues

Do not use metallic sponges or sharp scrapers as they will damage the surfaces.

Use ordinary non-abrasive products with the aid of wooden or plastic utensils if necessary. Rinse thoroughly and dry with a soft cloth or a microfiber cloth.

4.5. Cleaning the appliance

Outer surface

1. Clean the outer surface with a neutral detergent, lukewarm water and a damp cloth.
2. Do not allow water to pass through the outer structure.

Inside

1. After each use, clean the inside walls with a damp cloth.
2. Do not allow water to enter the ventilation holes of the microwave oven.
3. If it has been some time since the last cleaning and the cavity of the microwave oven is dirty, put a glass of water on the tray and connect the microwave at maximum power for 4 minutes. The steam that is released will soften the dirt, which will be easy to clean with a soft cloth.

Important! The appliance should not be cleaned with steam cleaning machines. The steam may reach the charged parts and cause a short circuit.

The most soiled stainless steel surfaces may be cleaned using a non-abrasive cleaning product.

Then they should be rinsed with hot water and dried well.

4. Clean accessories after each use. If they are very dirty, steep them first and then use a brush and a sponge. The accessories may be washed in the dishwasher. Ensure that the rotating plate and respective base are always clean.



Cleaning and Maintenance

Door, door-hinges and front of the appliance

1. These parts must always be clean, especially the contact surfaces between the door and the front of the appliance, so that there are no leaks.
2. To clean, use a neutral detergent and lukewarm water. Dry with a soft cloth.

Mica covers

Always keep the mica covers clean. Food remaining in the covers may deform it or produce sparks if they go on fire. Therefore, they should be cleaned on a regular basis, but abrasive cleaning products or sharp objects should not be used. Do not remove the covers, to avoid any risk.

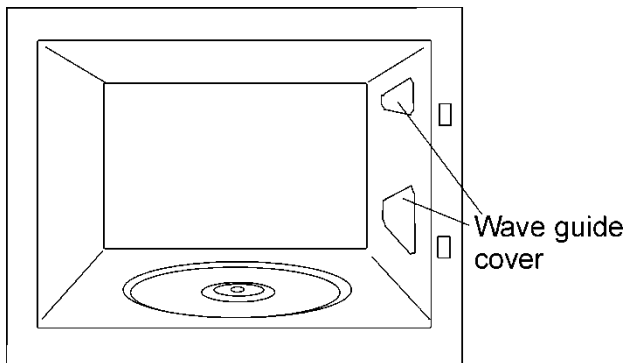

4.6. Troubleshooting

The appliance does not function properly:

- Is the power plug correctly inserted in the socket?
- Is the door properly closed? The door should make an audible click when it closes.
- Are there any foreign bodies between the door and the ring?

The foods do not heat up or they heat very slowly:

- Did you use a metallic dish by mistake?
- Did you select the right operating time and power level?
- Did you place a larger or colder amount of food than usual in the microwave?

The food is too hot, dry or burned:

- Did you select the right operating time and power level?

The display shows "HOT"!

- The temperature in the components compartment reached a safety limit. Check the installation conditions.

There are noises while the appliance is in operation:

- Is there an electrical arch inside the microwave?
- Is the dish coming into contact with the walls of the cavity?
- Are there loose skewers or spoons inside the microwave?

The inside lighting does not come on:

- If all of the functions are operating correctly, the bulb is probably blown. You may continue to use the appliance.
- The light bulb may only be replaced by the Technical Support Service.

The power cable is damaged

- The power cable must be replaced by the manufacturer, authorised agents or technicians that are qualified to perform this task, in order to avoid dangerous situations and because special tools are needed.



If the problem has not been resolved or in the case of other types of fault, contact your local technical support centre.



All repairs must be performed by specialised technicians.



5.1. Technical Features

AC voltage	(See characteristics plate)
Fuse	8 A / 250 V
Power required	1200 W
Grill power	1000 W
Microwave output power	850 W
Microwave frequency	2450 MHz
Outer dimensions (W×H×D)	595 × 390 × 340 mm
Cavity dimensions (W×H×D)	305 × 210 × 305 mm
Oven capacity	18 l
Weight	18.6 kg

5.2. Installation Instructions

Use the “open” button to open the door and remove all packaging materials. Then clean the inside and the accessories with a damp cloth and dry them. Do not use abrasive or strong-smelling products.

Ensure that the following parts are in good condition:

- Door and hinges
- Front of the microwave
- Inner and outer surfaces of the appliance

DO NOT USE THE APPLIANCE if you notice any kind of defect in the aforementioned parts. If this occurs, contact the After Sales Service.

Place the appliance on a stable, flat surface.

Fit the rotating base in the centre of the microwave cavity and place the rotating plate on top until it clicks into position. Whenever the microwave is used, both the rotating plate and the respective base must be inside the oven and correctly positioned. The rotating plate turns clockwise and anti-clockwise.

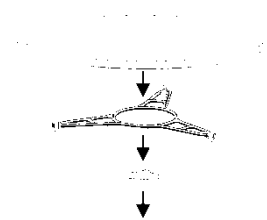

Warning! The microwave oven may be wrapped in a protective film. Before switching it on for the first time, carefully remove this film, starting at the underside.

In order to ensure proper ventilation for the appliance, install the frame in the correct way. Please refer to the following pictures:

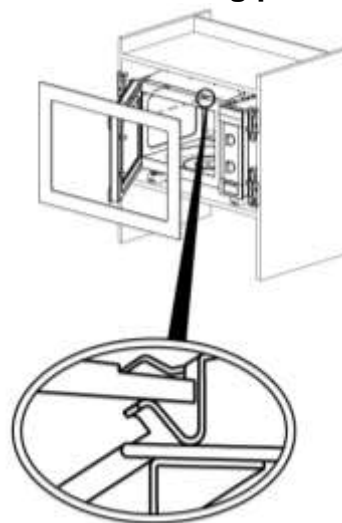

Warning: after installing the microwave, it is necessary to guarantee access to the electrical socket.

During installation, ensure that the power cable does not come into contact with the back of the appliance, because the high temperatures may damage the cable.

If you are installing a microwave and a conventional oven in the same column, the microwave must not be placed under the oven, because of the formation of condensation.

The electrical installation is to be set up so that the appliance can be isolated from the mains with a minimum 3mm all-pole contact separation.

Suitable separation devices include e.g. cutouts, fuses (screw fuses are to be taken out of the holder), RCD's and contactors. This installation must comply with current regulations.

If the electrical connection is done through a plug and this remains accessible after installation, then it is not necessary to provide the mentioned separation device.

Protection against electric shock must be provided by the electrical installation

Warning: The oven must be earthed.

The appliance must not be placed in the vicinity of heating elements, radios or television sets.

In case of fault, the manufacturer and the seller will not accept any responsibility if the installation instructions have not been properly followed.

Installation Images/ Installations-Images / Imágenes de Instalación / Imagens de Instalação

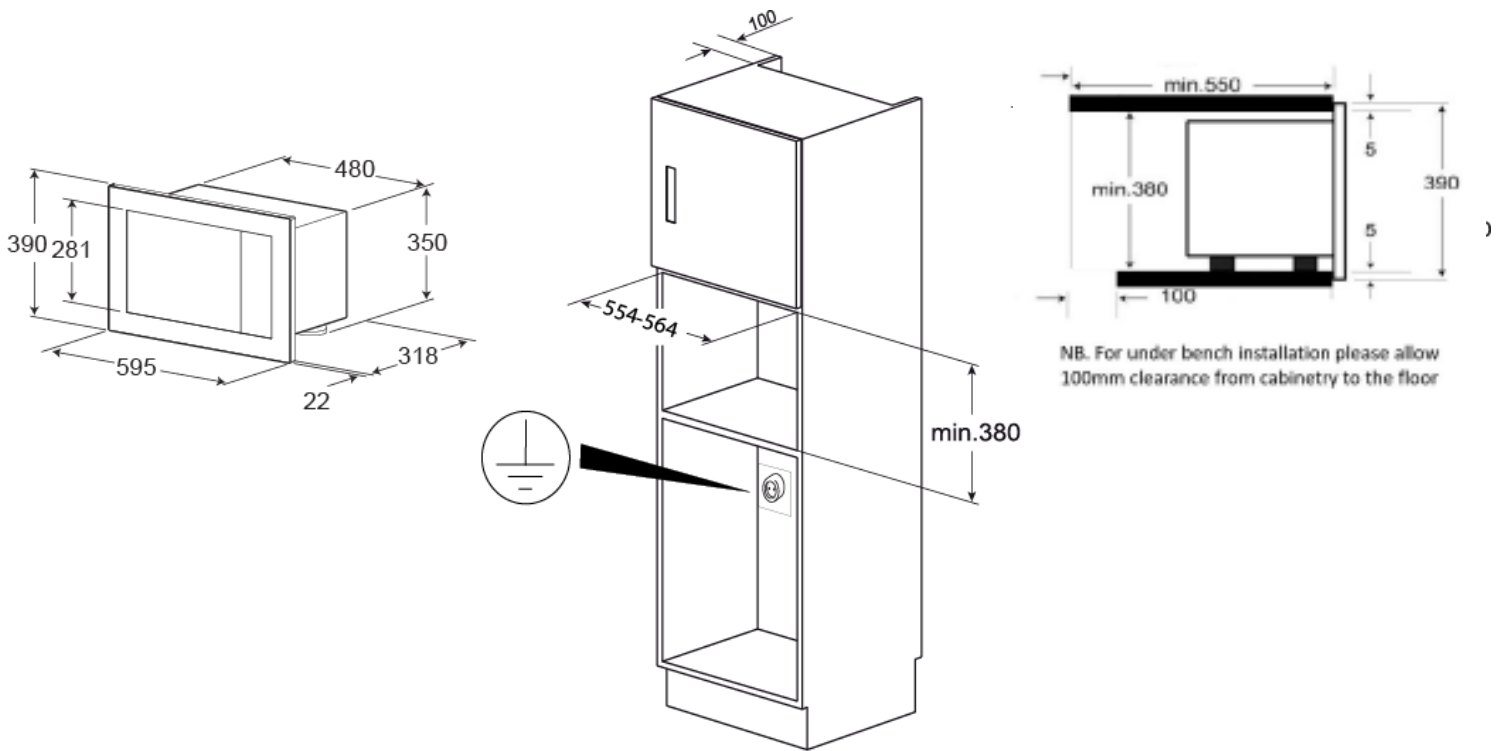
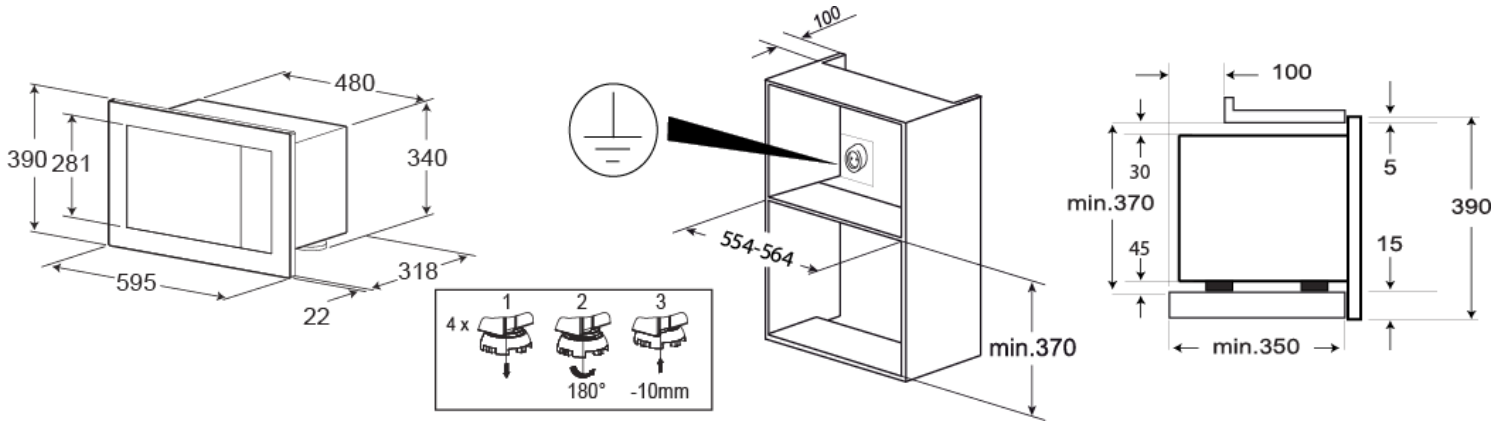

NB. For under bench installation please allow 100mm clearance from cabinetry to the floor