



User Manual

V190SG2E-BK



Important information that may impact your Manufacturer's Warranty

Adherence to the directions for use in this manual is extremely important for health and safety. Failure to strictly adhere to the requirements in this manual may result in personal injury, property damage and affect your ability to make a claim under the Vintec manufacturer's warranty provided with your product. Products must be used, installed and operated in accordance with this manual. You may not be able to claim on the Vintec manufacturer's warranty in the event that your product fault is due to failure to adhere this manual.

Warning.

In case this appliance contains hydrocarbon refrigerant please refer to guidelines listed below.

As the appliance contains a flammable refrigerant, it is essential to ensure that the refrigerant pipes are not damaged.

Standard EN378 specifies that the room in which you install your appliance must have a volume of 1m³ per 8 g of hydrocarbon refrigerant used in the appliances. This is to avoid the formation of flammable gas/air mixtures in the room where the appliance is located in the event of a leak in the refrigerant circuit. The quantity of the refrigerant used in your appliance is indicated on the rating plate.

WARNING: Keep ventilation openings in the appliance's cabinet or in the built-in structure clear of obstruction

WARNING: Do not use other **mechanical devices** or other means to accelerate the defrosting process than those recommended by the manufacturer

WARNING: Do not damage the refrigerant system

WARNING: Do not use **electrical appliances** inside the refrigerated storage compartment, unless they are of a type recommended by the manufacturer

WARNING: Do not expose the appliance to rain

WARNING: This appliance is not intended for use by young children or infirm persons unless they have been adequately super-

vised by a responsible person to ensure that they can use the appliance safely. Young children should be supervised to ensure that they do not play with the appliance

- Always keep the keys in a separate place and out of reach of children
- Before servicing or cleaning the appliance, unplug the appliance from the mains or disconnect the electrical power supply
- If the supply cord is damaged, it must be replaced by the manufacturer, its service agent, or similarly qualified persons in order to avoid a hazard
- **Relevant for Australia:** Supply cord fitted with a plug complies with AS/NZS 3112.
- Frost formation on the interior evaporator wall and upper parts is a natural phenomenon. Therefore, the appliance should be defrosted during normal cleaning or maintenance
- Please note that changes to the appliance construction will cancel all warranty and product liability
- This appliance is intended to be used exclusively for the storage of wine

CLASS 1 LED PRODUCT

Get to know your wine cooler

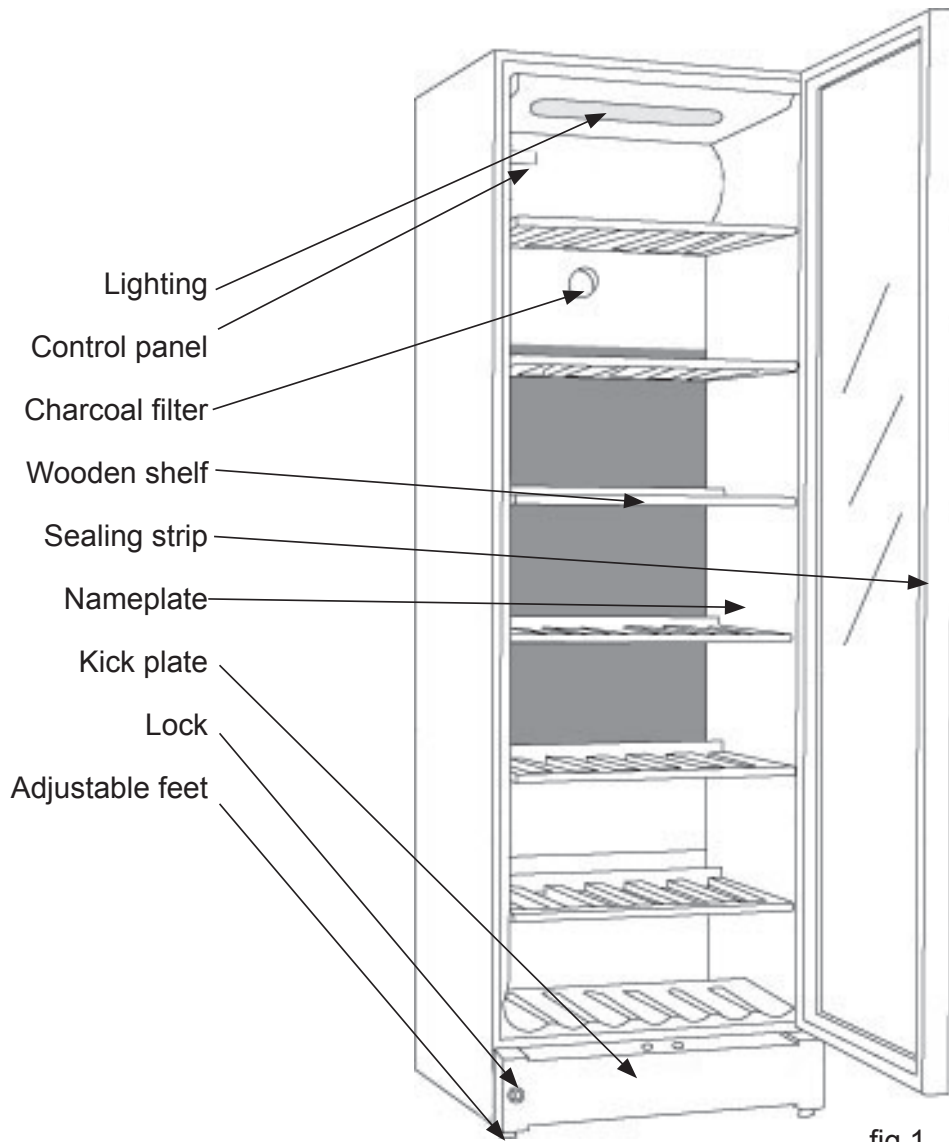

fig.1

Before use.

On receipt, check to ensure that the appliance has not been damaged during transport. Transport damage should be reported to the local distributor before the wine cooler is put to use.

Remove the packaging. Clean the inside of the cabinet using warm water with a mild detergent. Rinse with clean water and dry thoroughly (see cleaning instructions). Use a soft cloth.

If during transport the appliance has been laid down, or if it has been stored in cold surroundings (colder than + 5°C), it must be allowed to stabilise in an upright position for at least an hour before being switched on.

Installation and start-up.

Placement.

For safety and operational reasons, the appliance must not be installed outdoors.

The appliance should be placed on a level surface in a dry, well ventilated room (max. 75% relative air humidity). Never place the appliance close to sources of heat such as cookers or radiators, and avoid placing it in direct sunlight.

Ambient temperature.

The climate class is stated on the nameplate (see page 7 and page 13). This specifies the optimum ambient temperature. Wine coolers with winter position, however, function at ambient temperatures as low as 5°C.

Climate class	Optimum room temperature
SN	+10 °C to +32 °C
N	+16 °C to +32 °C
ST	+18 °C to +38 °C
T	+18 °C to +43 °C

Installation

The surface on which the appliance is to be placed must be level. Do not use a frame or similar.

The appliance can be installed as a free-standing unit against a wall, built into a kitchen element, or lined up with other appliances (figs 2-3).

Ventilation and dimensions

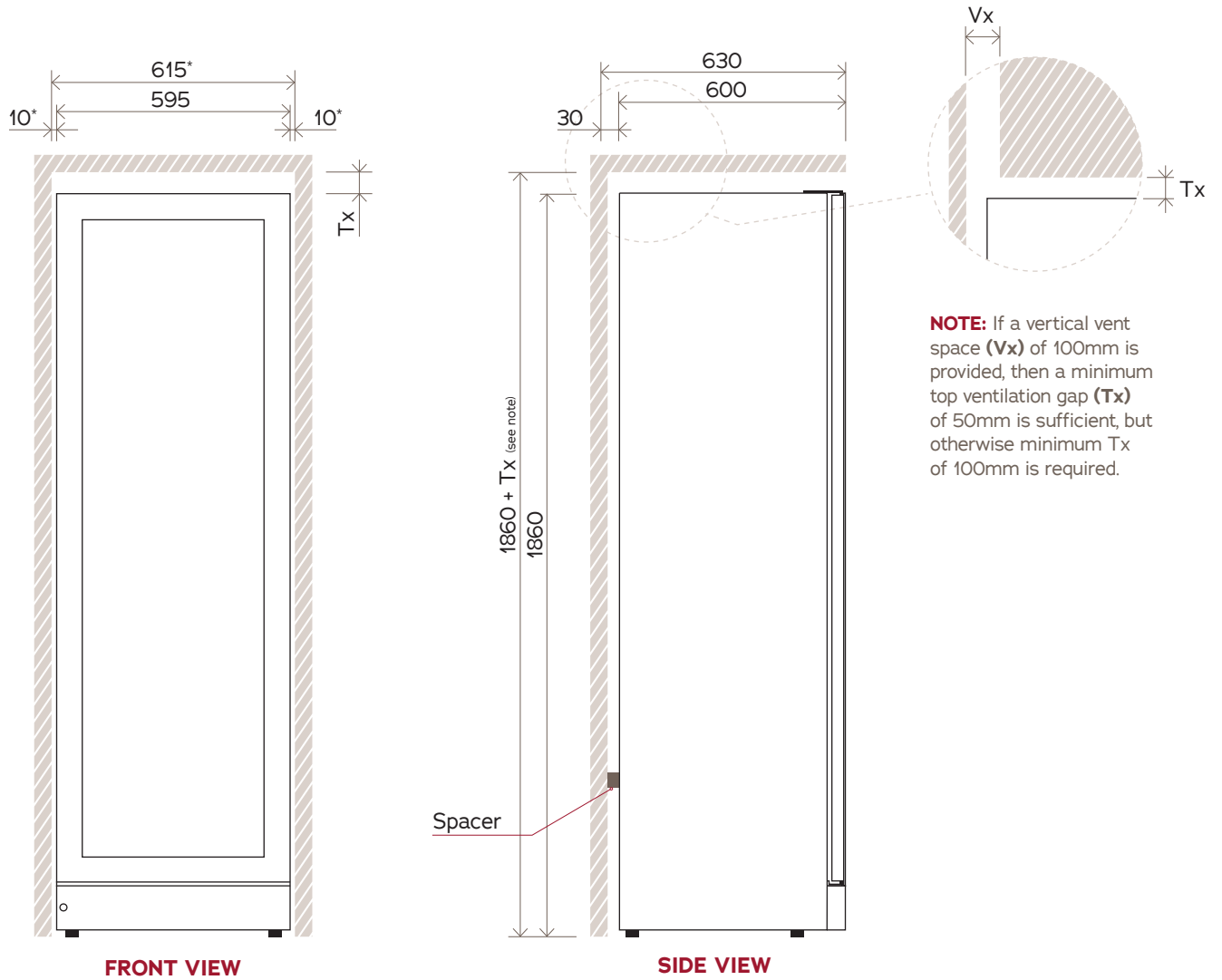

NOTE: Illustrations not to scale.
All dimensions in millimetres.

* Minimum 10mm required whether proud-fit or flush-fit, however 30mm is recommended on the opening edge for easy finger grip access when installed flush-fit.

The distance pieces on the rear of the appliance ensure sufficient air circulation. Fit the two caps supplied with the appliance as shown in fig. 7.

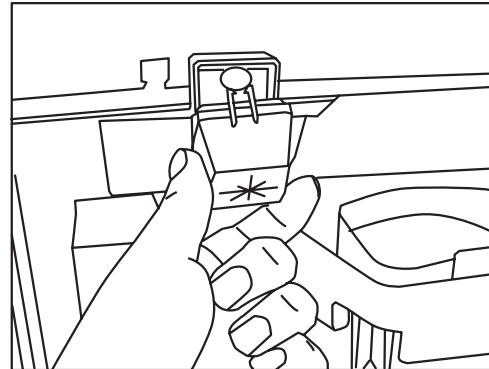

fig. 7

Setting up.

It is important that the appliance be absolutely level. It can be levelled by screwing the adjustable feet at the front of the appliance up or down (fig 8). Use a spirit level to check that the appliance is absolutely level sideways.

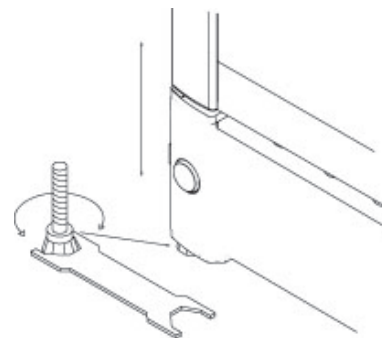
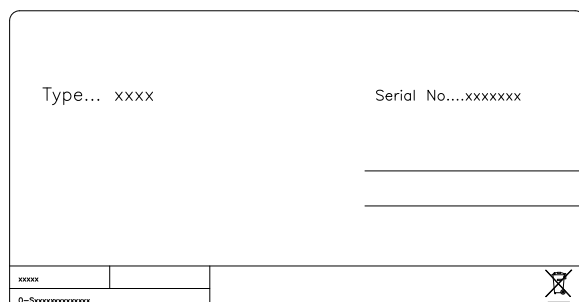

fig. 8

Technical data.

This device complies with relevant EU directives including Low Voltage Directive 2006/95 EEC. and Electromagnetic Compatibility Directive 2004/108/EC

The rating/name plate provides various technical information as well as type and serial number.



Max. 85 kg.

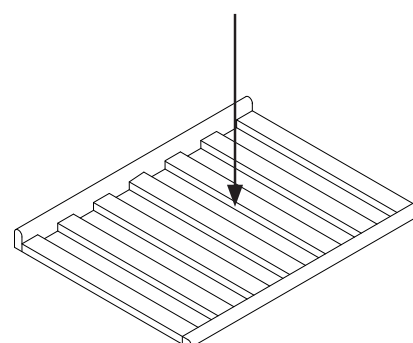

Operation and function.

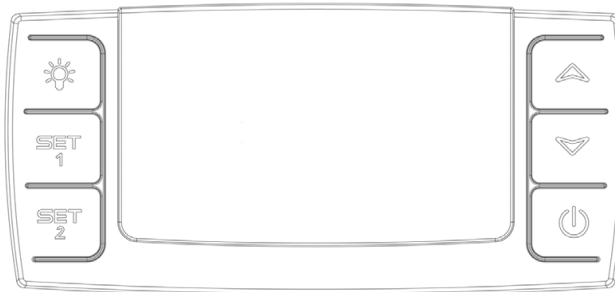

fig. 9

Electronic control

The electronic control ensures that the temperatures set at the top and at the bottom of the appliance are maintained. This is achieved by means of an advanced control of the refrigeration system, the heating element, and the fan. The set temperature will be stored in the event of power failure.

The electronic control has the following functions:

- On/off switch
- Light switch*
- Temperature setting
- Temperature indication
- Alarm for too high and too low temperatures
- Door alarm

* The light may either be turned on constantly or only when the door is open.

Temperature indication

The display shows the actual temperature. The upper digits of the display indicate the temperature at the top of the appliance, and the lower digits of the display indicate the temperature at the bottom of the appliance. The temperature indicator is equipped with

a built-in filter which simulates the actual temperature in the bottles. Consequently, the indicator does not react on short-term fluctuations of the air temperature

Temperature setting

The thermostat is equipped with a child lock device. This device is activated by pushing the “up and down” buttons simultaneously. After approx. 3 seconds “PoF” flashes in the display. Then the actual temperatures are shown as usual. In addition, the set temperatures can be shown by pushing SET1 and SET2, respectively.

The child lock device is cancelled by pushing the “up and down” buttons simultaneously. After approx. 3 seconds “Pon” flashes in the display, and the temperature can be set.

Temperature setting at the top of the appliance

Push SET1. Then the temperature at the top of the appliance can be adjusted up and down by means of the “up and down” buttons. The temperature can be adjusted from 8 to 22°C, however so that the temperature cannot be set at a lower temperature than the actual set point for the bottom temperature sensor.

Temperature setting at the bottom of the appliance

Push SET2. Then the temperature at the bottom of the appliance can be adjusted up and down by means of the “up and down” buttons. The temperature can be adjusted from 5 to 22°C, however so that the temperature cannot be set at a higher temperature than the actual set point for the upper temperature sensor.

Alarm devices

There is a sub-alarm for the low-temperature sensor and an excess-alarm for the high-temperature sensor.

The alarm consists of a beeper and a warning on the display. (⚠)

Alarm for high temperature: beep sound + alternating display of “HtA” and actual temperature

Alarm for low temperature: beep sound + alternating display of “LtA” and actual temperature

The alarm temperature depends on the set points.

The beep sound can be cancelled by pushing a random thermostat button. Push the on/off button to erase the display alarm, first for cancelling the alarm, then again for restarting the compressor.



Door alarm

When the door has been open for more than 2 minutes the door alarm is activated.

Light

To turn off the lights, press once 

Permanent lighting

For presentation purposes of your wine, you can turn the lights permanently. Please press the light switch image  twice. To switch off the lights press on  again.

Two-zone setting for serving temperature

Typical serving temperature settings for the top and bottom sections are 16°C and 6°C respectively. With these settings, a suitable temperature gradient will be achieved in the cabinet for the storage of various types of wine distributed from top to bottom as follows:

- heavy red wines +16 to +19°C
- rosé and light red wines +12 to +16°C
- white wines +10 to +12°C
- champagne and sparkling wines +6 to +8°C

It is recommended that wine be served at a temperature which is a couple of degrees lower than the desired drinking temperature as the wine will be warmed slightly when it is poured into the glass.

Single-zone setting for long-term storage

For long-term wine storage, the top and bottom sections should both be set at 12°C. With identical settings for the top and bottom sections, the controls will maintain an even temperature throughout the cabinet. However, the temperature in the room will gradually affect the temperature in the cabinet through its door and sides, creating a slight temperature gradient from top to

bottom. The controls will maintain the set temperature at the bottom of the cabinet, and any deviation from the setting will therefore occur at the top.

The difference will vary from 0 to 3°C, depending on the ambient temperature.

Defrosting, cleaning and maintenance.

Automatic defrosting.

The wine cooler is defrosted automatically. Defrost water runs through a pipe and is collected in a tray above the compressor where the heat generated by the compressor causes it to evaporate. The defrost water tray should be cleaned at intervals.

Cleaning.

Before cleaning the appliance, unplug it from the main supply. The cabinet is best cleaned using warm water (max. 65°C) with a little mild detergent. Never use cleaning agents that scour. Use a soft cloth. Rinse with clean water and dry thoroughly. The defrost water channel, in which condensation from the evaporator runs, is located at the bottom of the rear inside wall of the cabinet and must be kept clean. Add a few drops of disinfectant, e.g. Rodalon, to the defrost water drain a couple of times a year, and clean the drain using a pipe cleaner or similar. Never use sharp or pointed implements.

The sealing strip around the door must be cleaned regularly to prevent discolouration and prolong service life. Use clean water. After cleaning the sealing strip, check that it continues to provide a tight seal.

Dust collecting on the condenser on the rear of the cabinet, the compressor and in the compressor compartment is best removed using a vacuum cleaner.

Fault finding.

Fault	Possible cause	Remedy
The appliance is not working.	<p>The appliance is switched off.</p> <p>Power failure; the fuse is blown; the appliance is not plugged in correctly.</p>	<p>Press the on/off switch.</p> <p>Check that power is connected. Reset the fuse.</p>
Water collects in the bottom of the cabinet.	The defrost water pipe is blocked.	Clean the defrost water channel and the drain hole on the rear wall of the cabinet.
Vibration or bothersome noise.	<p>The appliance is not level. The appliance is resting against other kitchen elements.</p> <p>Containers or bottles inside the cabinet are rattling against one another.</p>	<p>Level the appliance using a spirit level.</p> <p>Move the appliance away from the kitchen elements or appliances it is in contact with. Move containers and/or bottles apart.</p>
Compressor runs continuously.	High room temperature.	Ensure adequate ventilation.
P1 is shown on the display.	The upper sensor is disconnected or short-circuited.	Call for service. The temperature within the entire cabinet is maintained at the higher of the two setpoints until the fault has been corrected.
P2 is shown on the display.	The lower sensor is disconnected or short-circuited.	Call for service. The temperature within the entire cabinet is maintained at the higher of the two setpoints until the fault has been corrected.

Warranty, spare parts and service.

Warranty disclaimer

Faults and damage caused directly or indirectly by incorrect operation, misuse, insufficient maintenance, incorrect building, installation or mains connection. Fire, accident, lightning, voltage variation or other electrical interference, including defective fuses or faults in mains installations.

Repairs performed by others than approved service centres and any other faults and damage that the manufacturer can substantiate are caused by reasons other than manufacturing or material faults are not covered by the warranty.

Please note that changes to the construction of the appliance or changes to the component equipment of the appliance will invalidate warranty and product liability, and the appliance cannot be used lawfully. The approval stated on rating plate will also be invalidated.

Transport damage discovered by the buyer is primarily a matter to be settled between the buyer and the distributor, i.e. the distributor must ensure that such complaints are resolved to the buyer's satisfaction.

Before calling for technical assistance, please check whether you are able to rectify the fault yourself. If your request for assistance is unwarranted, e.g. if the appliance has failed as a result of a blown fuse or incorrect operation, you will be charged the costs incurred by your call for technical assistance.

Disposal

Information for Users on Collection and Disposal of Old Equipment and used Batteries



These symbols on the products, packaging, and/or accompanying documents mean that used electrical and electronic products and batteries should not be mixed with general household waste. For proper treatment, recovery and recycling of old products and used batteries, please take them to applicable collection points, in accordance with your national legislation and the Directives 2002/96/EC and 2006/66/EC.

By disposing of these products and batteries correctly, you will help to save valuable resources and prevent any potential negative effects on human health and the environment which could otherwise arise from inappropriate waste handling.

For more information about collection and recycling of old products and batteries, please contact your local municipality, your waste disposal service or the point of sale where you purchased the items.

Penalties may be applicable for incorrect disposal of this waste, in accordance with national legislation.



For business users in the European Union.

If you wish to discard electrical and electronic equipment, please contact your dealer or supplier for further information.

[Information on Disposal in other Countries outside the European Union]

These symbols are only valid in the European Union. If you wish to discard this product, please contact your local authorities or dealer and ask for the correct method of disposal.

Note for the battery symbol (bottom two symbol examples):



This symbol might be used in combination with a chemical symbol. In this case it complies with the requirement set by the Directive for the chemical involved.

Safety instructions (See also Warning page 2).

1. There is a name plate inside the cabinet. The name plate provides various technical information and a safety notice with a yellow flame triangle label, name and chemical symbol of the refrigerant.
2. The refrigerator contains flammable refrigerant (R600a: iso-butane). Requirements to ensure gas safety and safe use of refrigerators:
 - The refrigeration system behind and inside the refrigerator contains refrigerant. Do not allow any sharp objects to come into contact with the refrigeration system.
 - Do not use other electric appliances inside the refrigerator.
 - Children should be supervised to ensure that the refrigerator should be used properly.
 - Do not use the mechanical devices or other means to accelerate the defrosting process, unless they are of the type recommended by the manufacturer.
 - Do not block the openings on the circumstances of the refrigerator.
 - In case of having damaged the refrigerant circuit, do not use electric items or fire equipments nearby, and open all windows to provide good ventilation. Please also contact your local maintenance agent to follow up.
 - The warning labels mentioned above should be kept throughout the life of the refrigerator. The user manual should be handed over to any person who would use or handle the refrigerator whenever the refrigerator would be transferred to another location and delivered to a recycling plant.



Reserving the right to alter specifications without prior notice.

8120804-01



FOR SALES IN AUSTRALIA AND NEW ZEALAND
APPLIANCE: ALL VINTEC/TRANSTHERM

This document sets out the terms and conditions of the product warranties for Vintec/Transtherm Appliances. It is an important document. Please keep it with your proof of purchase documents in a safe place for future reference should there be a manufacturing defect in your Appliance. This warranty is in addition to other rights you may have under the Australian Consumer Law.

1. In this warranty:

- (a) 'ACL' or 'Australian Consumer Law' means Schedule 2 to the Competition and Consumer Act 2010;
- (b) 'Appliance' means any Electrolux product purchased by you and accompanied by this document;
- (c) 'ASC' means Electrolux's authorised serviced centres;
- (d) 'Vintec/Transtherm' is the brand controlled by Electrolux Home Products Pty Ltd of 163 O'Riordan Street, Mascot NSW 2020, ABN 51 004 762 341 in respect of Appliances purchased in Australia and Electrolux (NZ) Limited (collectively "Electrolux") of 3-5 Niall Burgess Road, Mount Wellington, in respect of Appliances purchased in New Zealand;
- (e) 'Warranty Period' means the period specified in clause 3 of this warranty;
- (f) 'you' means the purchaser of the Appliance not having purchased the Appliance for re-sale, and 'your' has a corresponding meaning.

2. Application: This warranty only applies to new Appliances, purchased and used in Australia or New Zealand and is in addition to (and does not exclude, restrict, or modify in any way) other rights and remedies under a law to which the Appliances or services relate, including any non-excludable statutory guarantees in Australia and New Zealand.

3. Warranty Period: Subject to these terms and conditions, this warranty continues for in Australia for a period of 24 months and in New Zealand for a period of 24 months, following the date of original purchase of the Appliance.

4. Repair or replace warranty: During the Warranty Period, Electrolux or its ASC will, at no extra charge if your Appliance is readily accessible for service, without special equipment and subject to these terms and conditions, repair or replace any parts which it considers to be defective. Electrolux may, in its absolute discretion, choose whether the remedy offered for a valid warranty claim is repair or replacement. Electrolux or its ASC may use refurbished parts to repair your Appliance. You agree that any replaced Appliances or parts become the property of Electrolux.

5. Travel and transportation costs: Subject to clause 7, Electrolux will bear the reasonable cost of transportation, travel and delivery of the Appliance to and from Electrolux or its ASC. Travel and transportation will be arranged by Electrolux as part of any valid warranty claim.

6. Proof of purchase is required before you can make a claim under this warranty.

7. Exclusions: You may not make a claim under this warranty unless the defect claimed is due to faulty or defective parts or workmanship. This warranty does not cover:

- (a) light globes, batteries, filters or similar perishable parts;
- (b) parts and Appliances not supplied by Electrolux;

- (c) cosmetic damage which does not affect the operation of the Appliance;
- (d) damage to the Appliance caused by:
 - (i) negligence or accident;
 - (ii) misuse or abuse, including failure to properly maintain or service;
 - (iii) improper, negligent or faulty servicing or repair works done by anyone other than an Electrolux authorised repairer or ASC;
 - (iv) normal wear and tear;
 - (v) power surges, electrical storm damage or incorrect power supply;
 - (vi) incomplete or improper installation;
 - (vii) incorrect, improper or inappropriate operation;
 - (viii) insect or vermin infestation;
 - (ix) failure to comply with any additional instructions supplied with the Appliance;

In addition, Electrolux is not liable under this warranty if:

- (a) the Appliance has been, or Electrolux reasonably believes that the Appliance has been, used for purposes other than those for which the Appliance was intended, including where the Appliance has been used for any non-domestic purpose;
- (b) the Appliance is modified without authority from Electrolux in writing;
- (c) the Appliance's serial number or warranty seal has been removed or defaced.

8. How to claim under this warranty: To enquire about claiming under this warranty, please follow these steps:

- (a) carefully check the operating instructions, user manual and the terms of this warranty;
- (b) have the model and serial number of the Appliance available;
- (c) have the proof of purchase (e.g. an invoice) available;
- (d) telephone the numbers shown below.

9. Australia: For Appliances and services provided by Electrolux in Australia: Electrolux goods come with guarantees that cannot be excluded under the Australian Consumer Law. You are entitled to a replacement or refund for a major failure and for compensation for any other reasonably foreseeable loss or damage. You are also entitled to have the Appliance repaired or replaced if the Appliance fails to be of acceptable quality and the failure does not amount to a major failure. 'Acceptable quality' and 'major failure' have the same meaning as referred to in the ACL.

10. New Zealand: For Appliances and services provided by Electrolux in New Zealand, the Appliances come with a guarantee by Electrolux pursuant to the provisions of the Consumer Guarantees Act, the Sale of Goods Act and the Fair Trading Act. Where the Appliance was purchased in New Zealand for commercial purposes the Consumer Guarantee Act does not apply.

11. Confidentiality: You accept that if you make a warranty claim, Electrolux and its agents including ASC may exchange information in relation to you to enable Electrolux to meet its obligations under this warranty.

Important Notice

Before calling for service, please ensure that the steps listed in clause 8 above have been followed.

<p>FOR SERVICE or to find the address of your nearest authorised service centre in Australia PLEASE CALL 1800 771 776 For the cost of a local call (Australia only)</p>	<p>AUSTRALIA ELECTROLUX HOME PRODUCTS 163 O'Riordan Street, Mascot NSW 2020 vintec.com.au</p>	<p>FOR ACCESSORIES PLEASE CALL 1800 666 778 For the cost of a local call (Australia only) or visit www.vintecclub.com</p>
<p>FOR SERVICE or to find the address of your nearest authorised service centre in New Zealand PLEASE CALL 0800 550 020 (New Zealand only)</p>	<p>NEW ZEALAND ELECTROLUX (NZ) Limited 3-5 Niall Burgess Road, Mount Wellington vintec.co.nz</p>	<p>FOR ACCESSORIES PLEASE CALL 0800 550 020 (New Zealand only) or visit www.vintecclub.com</p>



Service and support

In the rare event that your Vintec cabinet does not perform to your satisfaction, contact our dedicated support team:

1800 771 776

concierge@vintecclub.com

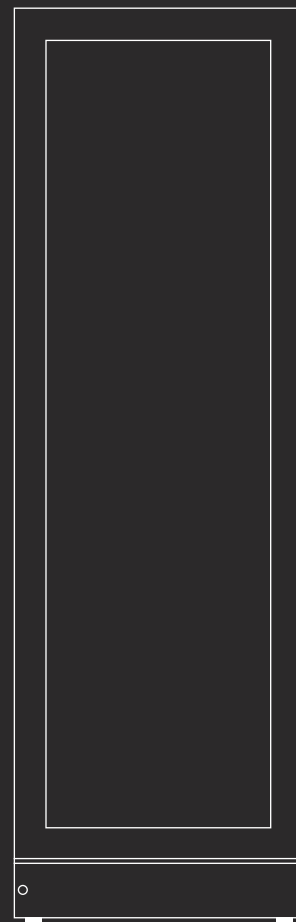

Vintec. We are part of the Electrolux Family. To add a touch of professional inspiration to your home, visit electrolux.com.au

Stay in touch and share your user experience by following us:

