

WINE MASTER

———— le temps d'être différent



Installation and user guide

(keep carefully)

WineARM15

DATA STATED ON THE RATING PLATE OF THE DEVICE :

- Model :
- Serial N° :
- Date of purchase :

IMPORTANT :

It is advisable to note the serial number above. This number will be necessary for any subsequent spare-part order.

01.03.2017

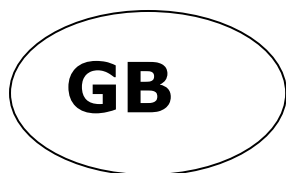

User guide

Table of contents

1. WINE CABINET BUILDING	5
1.1. Air rejection	5
1.2. Wine cabinet insulation	5
1.2.1. Insulation of walls, ceiling and floor	6
1.2.2. Doors.....	7
2. INSTALLATION OF THE AIR CONDITIONER WINEMASTER®	7
2.1. Ceiling drilling	7
2.2. Fitting the air conditioner	8
2.2.1. Fitting the air conditioner from the inside of the wine cabinet	8
2.2.2. Fitting the air conditioner from above	8
2.2.3. Setting up the water flow	9
2.2.4. Air flow ventilation	10
2.2.5. Fitting the thermostat.....	11
2.2.6. Fitting the cover.....	11
3. START USING THE AIR CONDITIONER WINEMASTER®	12
3.1. Plug-in the air conditioner.....	12
3.2. Using the air conditioner	12
3.2.1. Setting the temperature	12
3.2.2. Stand by mode	13
3.2.3. Automatic defrost	13
3.2.4. Manual defrost.....	13
4. MAINTENANCE OF THE AIR CONDITIONER WINEMASTER®	13
4.1. Filter maintenance	13
4.2. Condensate evacuation drain	14
5. WARRANTY	15
5.1 Contractual warranty.....	15
5.2. 2 years contractual warranty	15
5.3. Warranty conditions.....	15
5.4. Exclusions and warranty limitations.....	15

Introduction

You purchased an air conditioner WINEMASTER® and we thank you for your confidence.

From conception to marketing, everything has been implemented to offer an exclusive and high quality product. Brainchild of a team who find in this a motivation to ever satisfy you, we hope that your wine conditioning unit WINEMASTER® will bring you great storage conditions and best wines aging for an incomparable pleasure.

Because the customer is at the heart of all our thoughts, we want to support you in your first steps and lead you towards the best use of your air conditioner every day. Thus, you will find in this manual technical information and practical advice to help you to deal with the essential steps to installation and use.

In order that your wine tasting remains moments to share, WINEMASTER guarantees you a sincere engagement, dedicated expertise and ongoing follow-up at your service!

The WINEMASTER team.



Technical data

	WINEARM15
Weight of the unit	31 kg
Dimensions (mm)	W908xD439xH316
Dimensions découpe	890 x 428
Temperature setting	Set to 12°C, adjustable between 8 and 18°C *
Outside maximum temperature	35°C **
Cooling power	500 W at 15°C **
Electric supply	235V-50 Hz + 3 m length cable
Absorbed electric power	400 W

The circuit breaker must be at least **16 Amps**.

* The insulation has to be in accordance with the volume of the cellar and the set temperature (see data page 6).

** The cooling performance is dependant from the outside temperature. Therefore, the set temperature of 12°C for the cellar cannot be maintained if the outside temperature reaches 35°C.

If the thermal safety functions too often, there is a risk for the compressor to be damaged. In all cases, it must be avoid that the **temperature in the evacuation room remains constantly at 35°C**, this high temperature should be limited to the summer period.

Technical drawing (dimensions in mm)

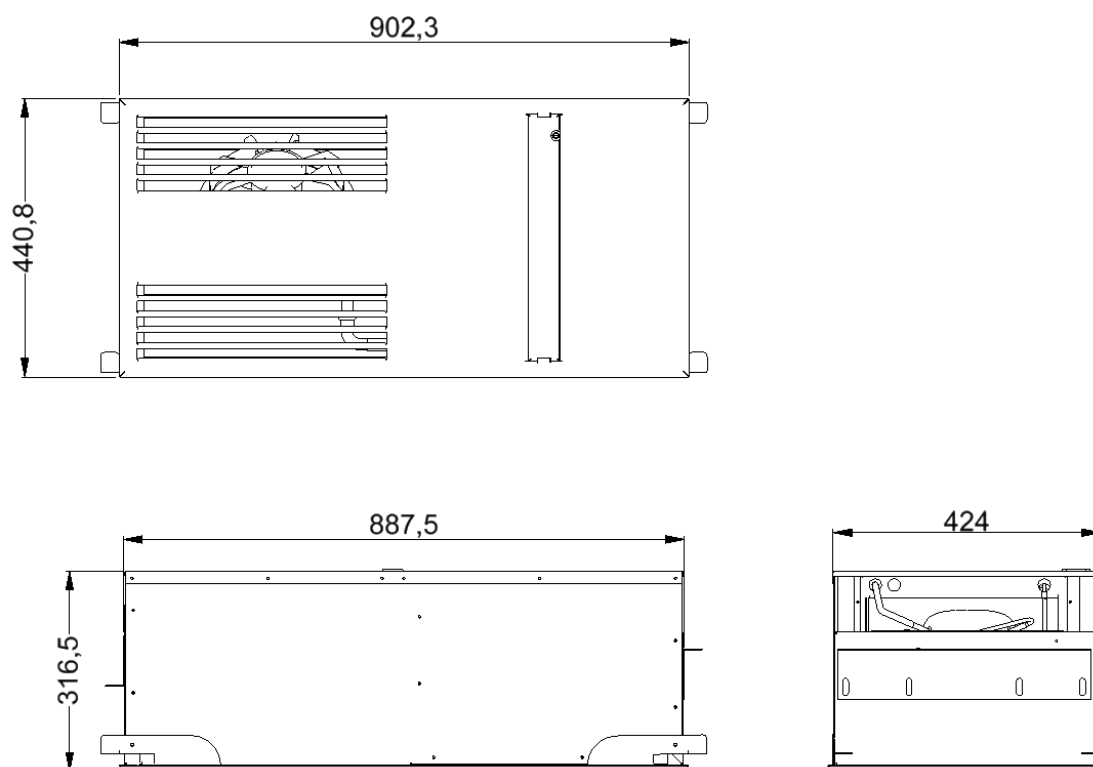

1. WINE CABINET BUILDING

The air conditioner is installed across the ceiling of the wine cabinet. For a correct functioning, the appliance releases air to the outside at about 20°C above the suction temperature.

1.1. Air rejection

The hot air produced by the air conditioner must be **properly vented** so that it's not sucked for the cooling.

Maximum and non permanent suction temperature $\leq 35^{\circ}\text{C}$

Ideal suction temperature $\approx 20^{\circ}\text{C}$

VENTILATED COLD OR « NO FROST » (schematic diagram)

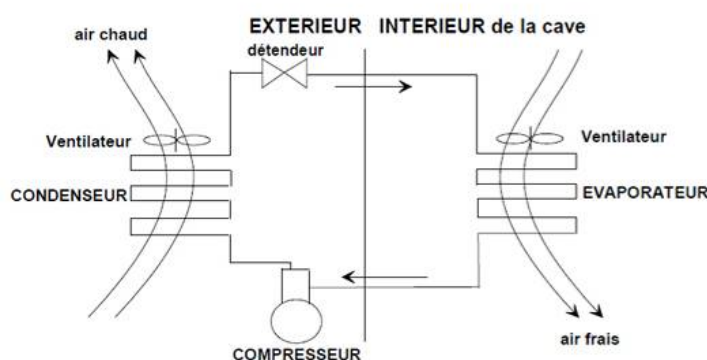

The advantages of « ventilated cold »:

- No frost other than on the evaporator.
- Automatic defrosting and maximized refrigeration efficiency.
- Cold distribution improved by a permanent air circulation (without air stratification).

The circulation of air allows maintaining the pre-selected temperature throughout the cellar

1.2. Wine cabinet insulation

Insulation is essential for an efficient functioning of the WINEMASTER®. An appropriate insulation enables to maintain a stable **temperature and humidity level**. The chart on the next page will allow you to determine the type and thickness of insulation needed in relation to the exterior volume of the cellar and the model of the WINEMASTER®, for an inside temperature of 12°C.

Complete insulation

→ The insulation elements must be assembled, preferably:

- By tongue and groove " panels or
- By panels fused together

→ **GOAL: To avoid parasitic input of heat and humidity, this would harm their regulation.**

In order to avoid moisture migration in the basement, it is necessary to install a vapor barrier where the wine cabinet is installed.

Insulation materials

Volume of the cellar (m ³)	Polystyrene expanded = 0,044 W/m°C (mm)	Polystyrene extruded = 0,030 W/m°C (mm)	Polyurethane foam = 0,025 W/m°C (mm)
2	25	20	20
3	30	25	20
4	40	30	25
5	45	30	25
6	50	35	30
8	60	45	40
10	80	55	45
12	90	65	55
15	110	80	70

1.2.1. Insulation of walls, ceiling and floor

Type of insulation panels

You can select among the following type of panels:

- Usual panels,
- « Complex panels »: insulation is covered with a with a cover material (plaster, mineral
- « Sandwich panels »: insulation is covered on each side with a wooden panel or plaster board.

Important: The covering of the panels **protects the insulation against damage and guarantees its longevity. Avoid using mineral fibres insulation** (glass wool, Rockwool, etc..) as they may accumulate moisture and lose their insulation power and avoid also thin film insulation that are not effective for cold.

DO YOU KNOW THAT?

Some insulating materials are damaged by rodents. If necessary, cover the insulation with a protective lining on the inside of the cellar to avoid presence of mouse or rats.

- **Polyurethane is an insulator that, due to its chemical composition, is not attacked by the rodents.**

Floor insulation

The floor of the cellar must be able to support the shelves and the stored wine. Thus, it's necessary to choose insulation with adequate compression strength.

Improve the load capacity of the insulation (particularly under the shelf legs) by using:

- « **Complex** » insulation panels covered by panels of higher load capacity.
- **Cover the insulation panel with a wooden panel** (at least 15 mm thickness), or every other appropriated material.

1.2.2. Doors

Door improves the insulation. Two solutions are possible:

- Glazed doors: use double glazing or even triple glazing with a good coefficient UG (max. 1.2 W /)
- In the case of solid doors, these must be insulated in the same way as the other walls

2. INSTALLATION OF THE AIR CONDITIONER WINEMASTER®



THE APPLIANCE MUST BE INSTALLED BY COMPLYING WITH THE NATIONAL ELECTRICAL INSTALLATION RULES



Necessary material (not delivered)



Material included in the box

2.1. Ceiling drilling

Cut the ceiling in order to create a cutout for the air conditioner

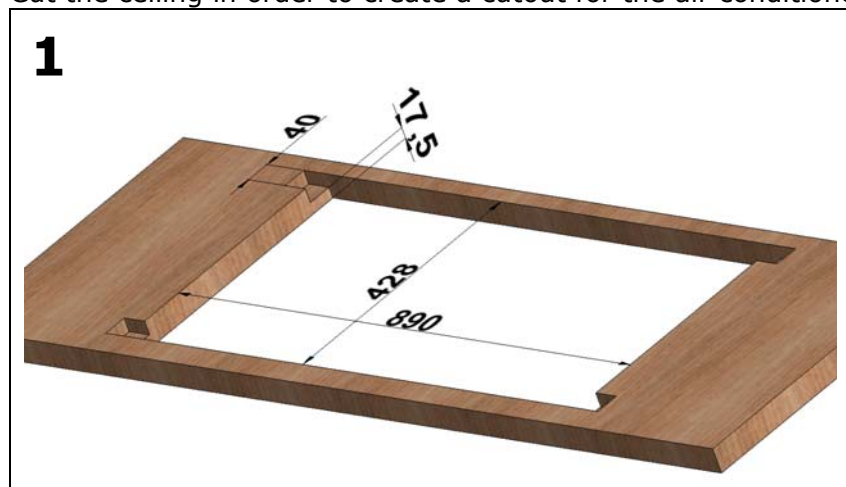

1
Cutting of the ceiling and adjustment of the notches if they are used

2.2. Fitting the air conditioner

2.2.1. Fitting the air conditioner from the inside of the wine cabinet

The air conditioner can be placed in the ceiling from inside the cabinet and locked with the 4 rotary tabs integrated in the air conditioner.

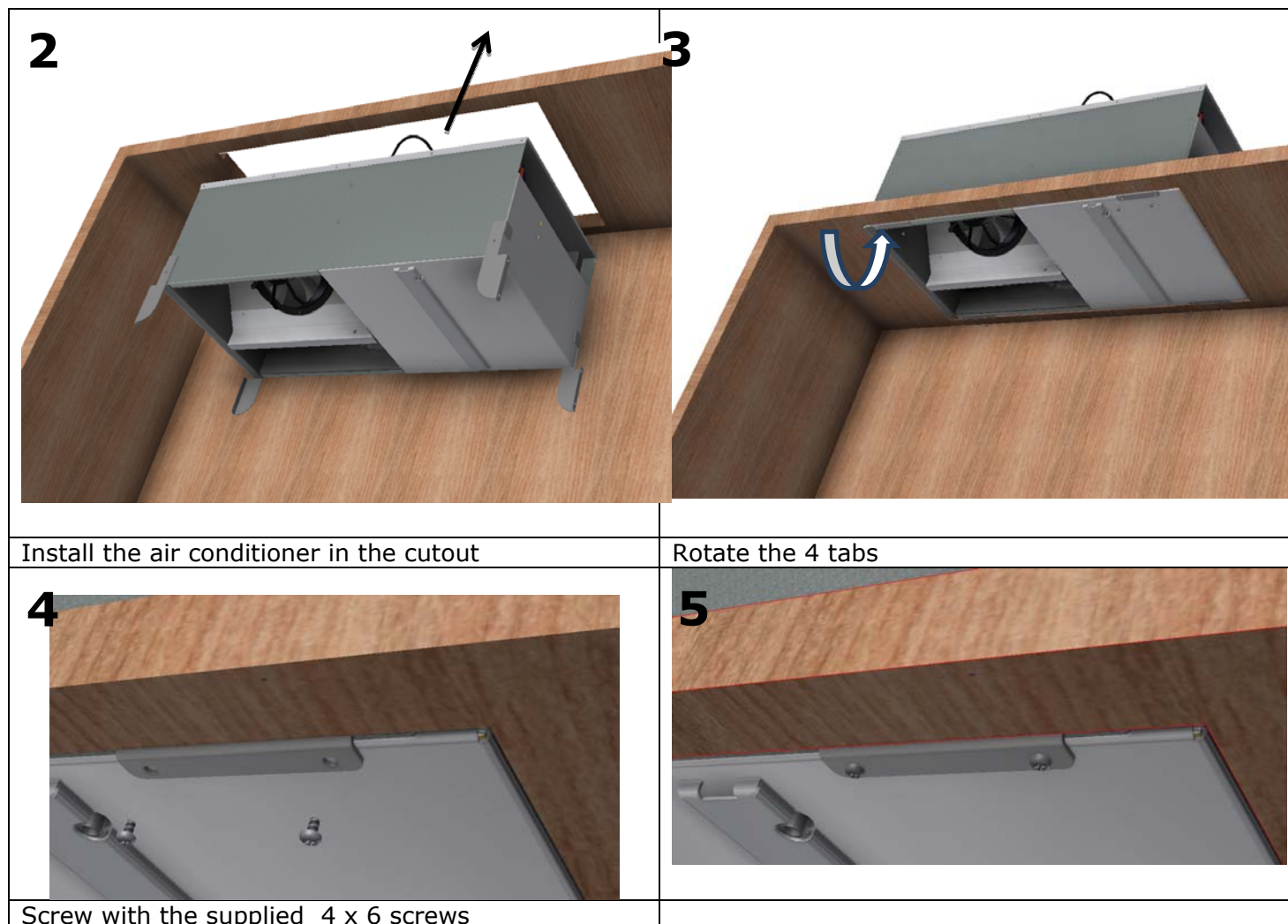

2.2.2. Fitting the air condition from above

In the case of a top installation, it is possible to disassemble the 4 rotary tabs used to hold the air conditioner and to use the brackets supplied.

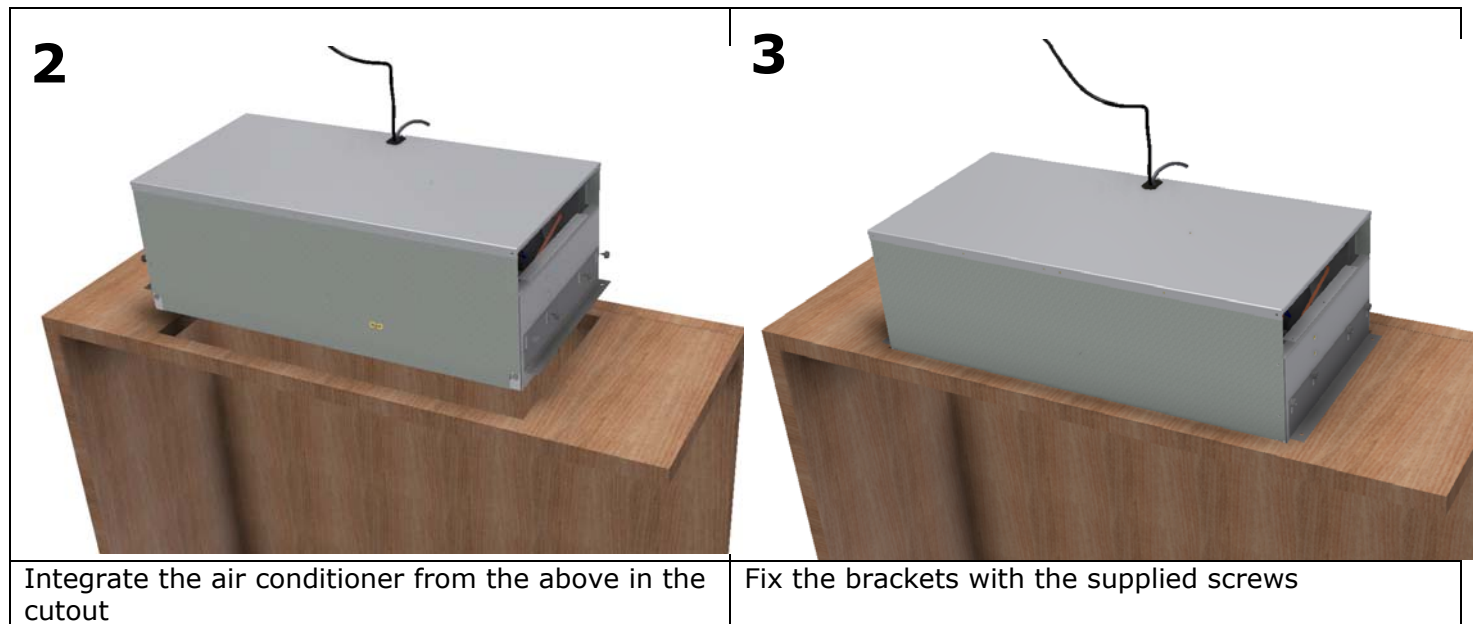

2.2.3. Setting up the water flow

The air conditioner has a condensate evaporation system. However, there is an overflow through which excess water can escape due to insufficient waterproofing of the cabinet or excessive opening of the doors. It can be connected by means of a PVC pipe supplied to a container.

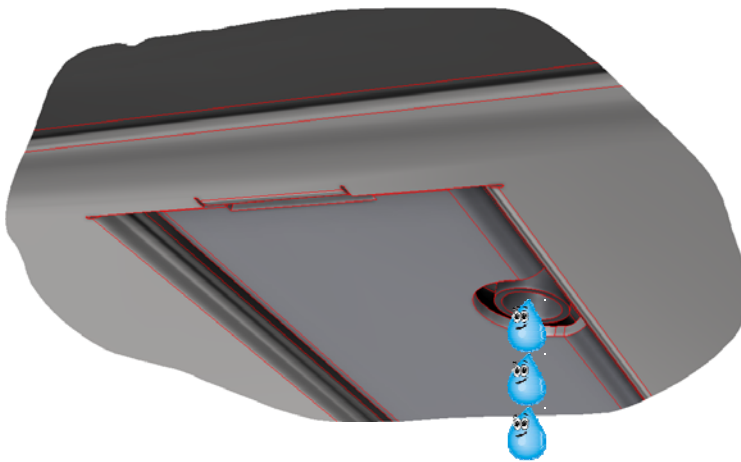

2.2.4. Air flow ventilation

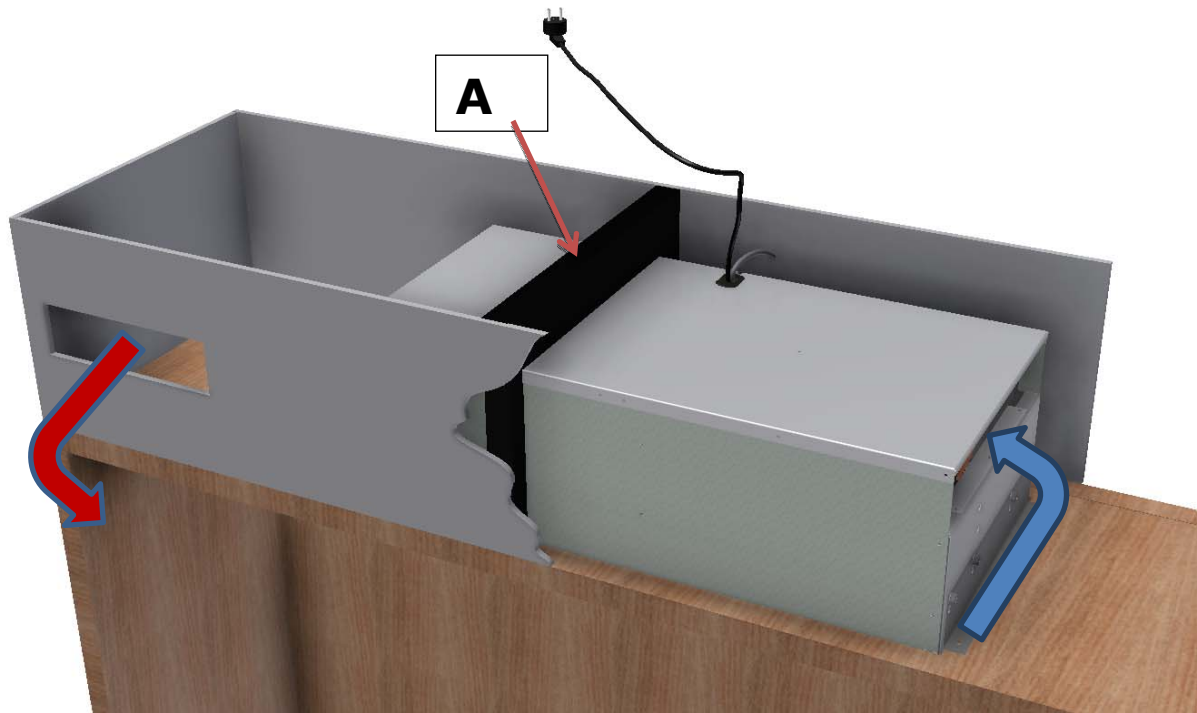

Separate the air flows. The free cross-section of each grid is 200 cm². Separation A is not provided.
Be sure to seal this separation.

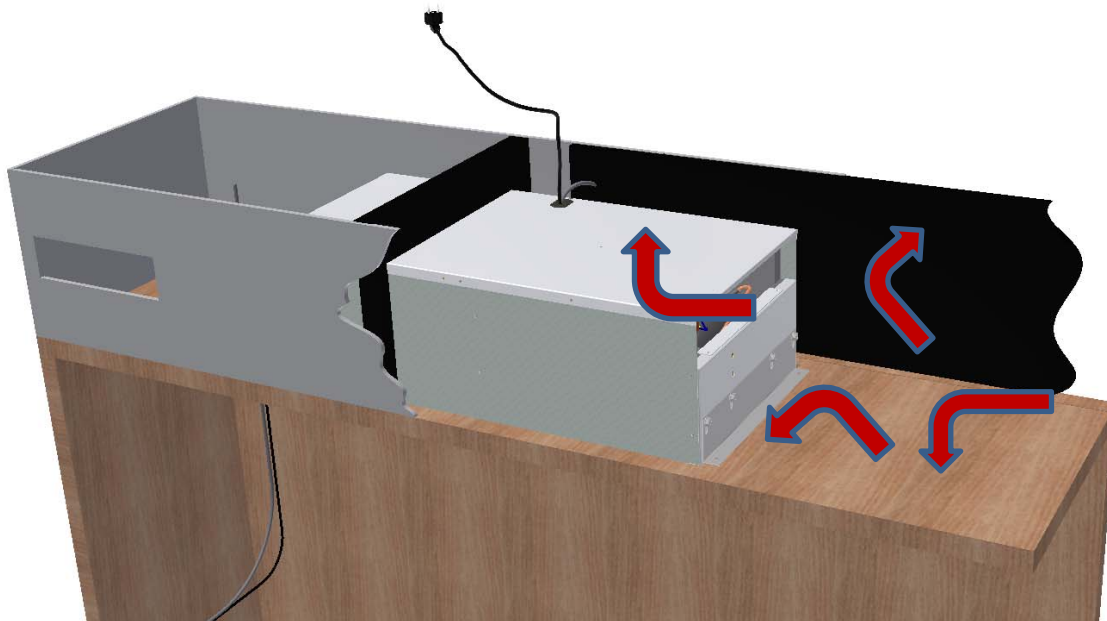

Additional sound insulation is possible. It is particularly useful for suction on all walls

2.2.5. Fitting the thermostat

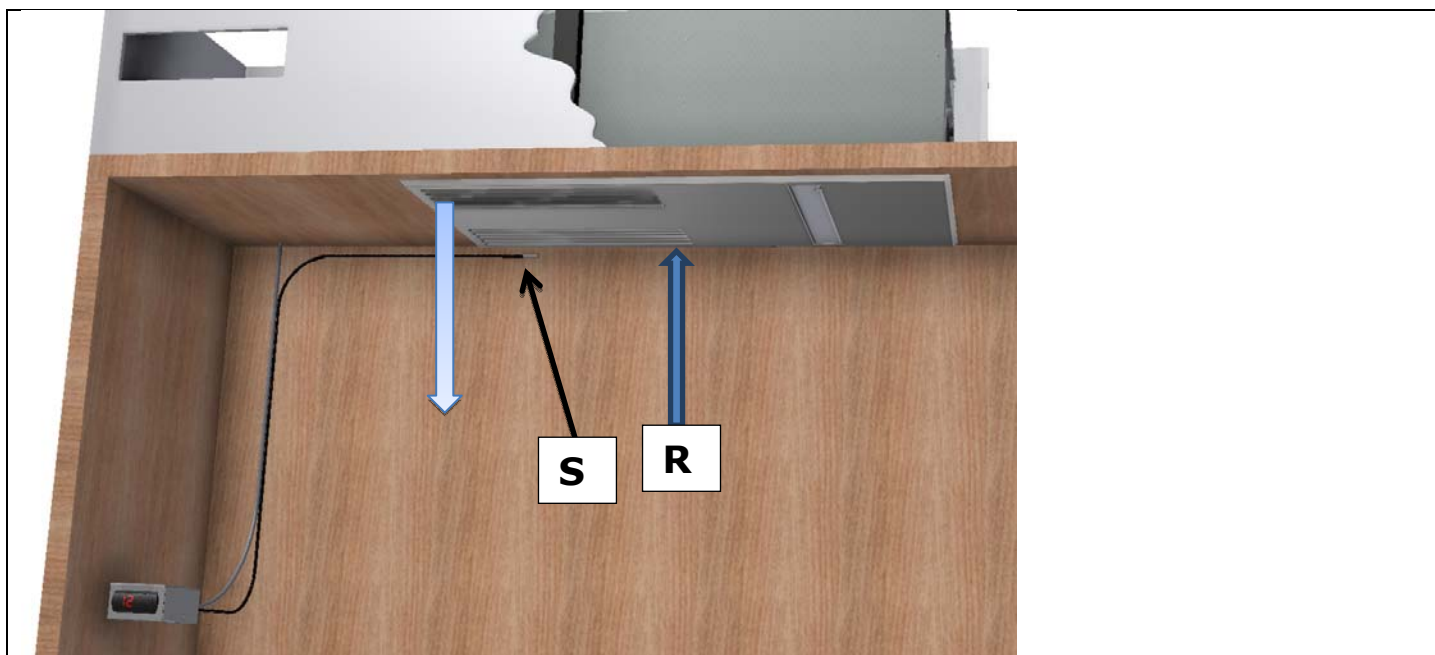

The thermostat can be placed in the cabinet or on the front or outside the cabinet. Its probe (S) must be placed towards the air intake area (R). It is advisable to ensure that the end of the probe does not touch the bulkhead and is in the air flow..



If the connecting cable is damaged, it has to be replaced by either the producer, his after sale service or qualified people in order to avoid any danger.

2.2.6. Fitting the cover

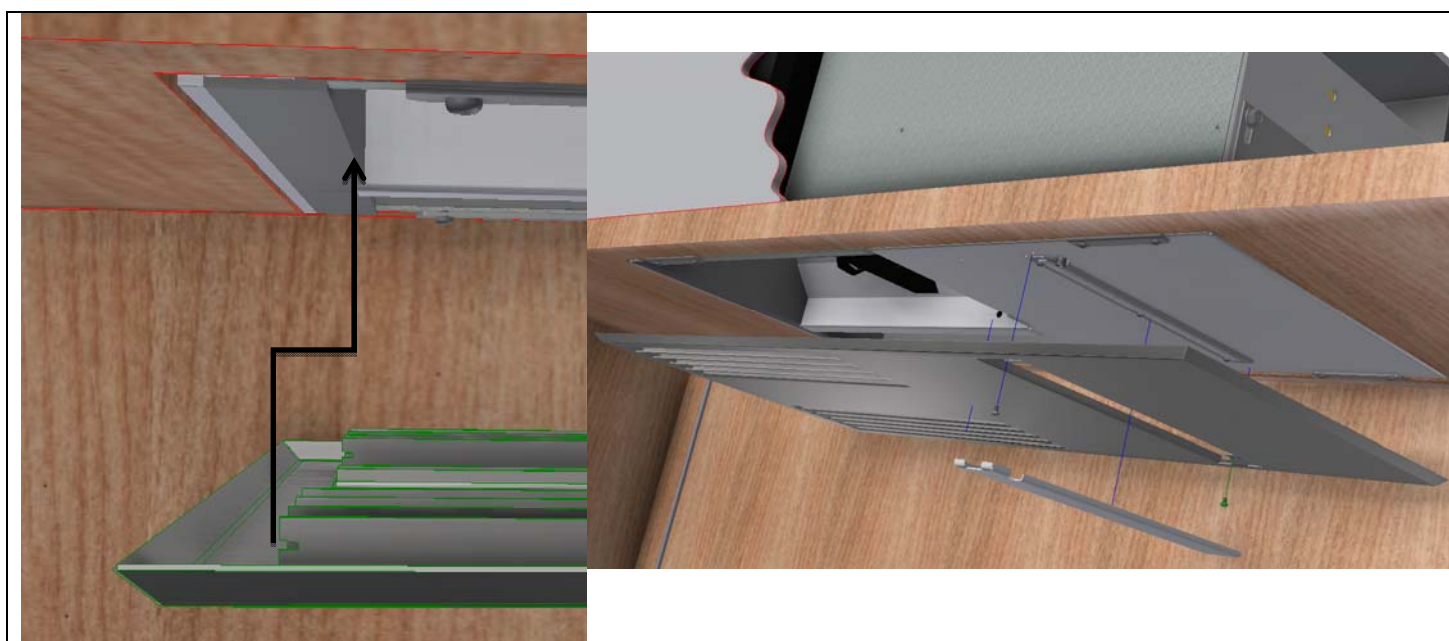

The cover is inserted on the left at the notches and then screwed. The cover is magnetic

↪ Important :

After transport or handling, wait for 24 hours before plug in the air conditioner.

3. START USING THE AIR CONDITIONER WINEMASTER®

The thermostat indicates the temperature into the wine cellar with a precision of 2°C. The thermostat is set at 12°C in the factory. During installation, the set temperature must be controlled and adjusted following our process (§3.2.1).

3.1. Plug in the air conditioner

When you start the air conditioner, the room temperature is displayed:





- If the temperature is higher than the thermostat setting: the air conditioner starts after a delay of 2 minutes.
- If the temperature is lower than the thermostat setting: the compressor does not start. Only the fan from inside unit works.

3.2. Using the air conditioner

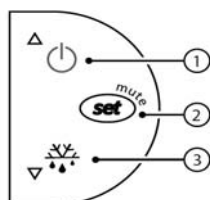
3.2.1. Setting the temperature



The setting of the targeted temperature is made as follows :

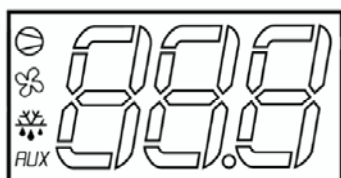

- Press on button  one second until the set point temperature flashes.
- Use the button  to increase the set point temperature.
- Use the button  to decrease the set point temperature.
- When the right temperature is set, press on button  to confirm.

Expansion of the main display symbols:



- Red light**  = cold mode engaged (compressor)
- Red light**  = cooling fan in high speed
- Red light**  and « dF » code = automatic defrost engaged

Red light *AUX* = heating mode engaged (resistance)

Red light  = alarm (a flashing message indicates the nature)

- « **IA** » code = external alarm or open door (depending model)
- « **DEF** » code = manual defrost engaged (see 3.2.4)

3.2.2. Standby mode

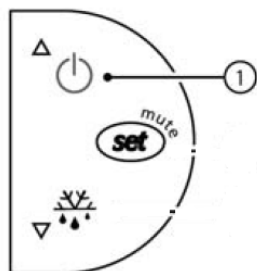

- Standby mode: maintain a 3 seconds pressure on button 1. The compressor stops and the fan turns at low speed.
- The thermostat shows « **OFF** » and alternatively the wine cellar temperature.
- To come back, press again during 3 seconds on button 1.
- The thermostat indicates « **ON** » during 1 second.

3.2.3. Automatic defrost

The program of the thermostat will run an automatic defrost time several times a day. During this operation, the compressor is stopped, only the fan is functioning at low speed. The condensate water produced during this period will be evacuated into the evaporation container located under the compressor inside the air conditioner Winemaster®. If necessary, the overflow is evacuated through the hole located next to the dust filter access door.

3.2.4. Manual defrost

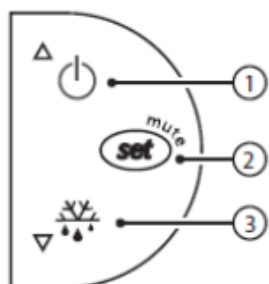

- The manual defrost is not necessary but can be achieved by a 3 seconds pressure on button 3. The compressor stops.
- The thermostat shows « **DEF** » and alternatively the wine cellar temperature.
- To come back, press again during 3 seconds on button 3.
- The thermostat indicates « **ON** » during 1 second

4. MAINTENANCE OF THE AIR CONDITIONER WINEMASTER®

4.1. Filter maintenance

The unit is equipped with a dust filter. This protects the air conditioner from fouling. The dust filter must be checked regularly and **replaced at least once a year**. The filter is accessible from the bottom of the air conditioner.



- Remove the magnetic cover
- Remove the 2 screws maintaining the shutter
- Remove the filter
- Put the new filter in place



SPOILED FILTER = DAMAGED AIR CONDITIONER

USE ONLY WINEMASTER® FILTERS ref. W1364.1

4.2. Condensate evacuation drain

Check that the condensate drain is not clogged and **clean it once a year.**

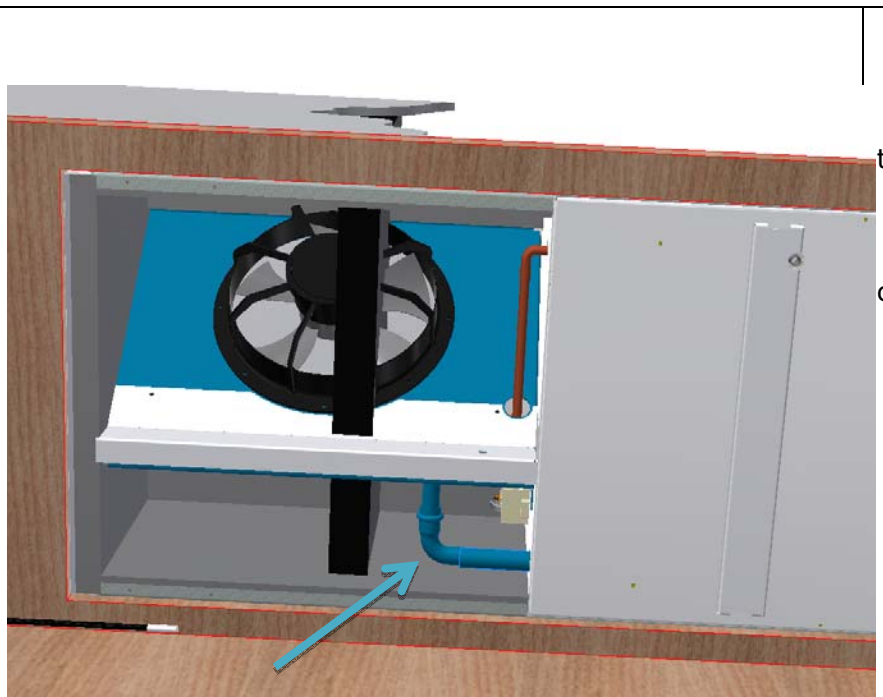

- Remove the cover (see § 2.2.6)
- The stainless steel elbow can be twisted
- Remove the deposits in the pipe
- Remount the elbow and the cover

5. WARRANTY

5.1. Contractual warranty

The contractual warranty is not exclusive, earnings for the benefit of the purchaser profit of the legal warranty against defects or hidden defects that applies under the conditions of article 1641 and following from the customer code.

5.2. 2 years contractual warranty

WINEMASTER offers a **2 years warranty** against any manufactured defect.

During this period of contractual warranty, WINEMASTER will replace any acknowledge defective part **Les interventions et retours devront être réalisés seulement après accord écrit du service après-vente FONDIS.**

5.3. Warranty conditions

The contractual warranty applies to all appliances installed and used in conformity with this « User Manual". His application is conditioned by the presentation of the purchase invoice or for lack of its copy.

5.4. Exclusions and warranty limitations

The warranty can refused in following cases:

- Insulation of the cellar or installation of the appliance not in compliance with the instructions of this guide.
- Damage due to negligence, lack of maintenance or incorrect use of the WINEMASTER® (particularly dirty filters).
- Exchange or repair of parts under warranty will not extend the 2 years warranty period

WINEMASTER cannot, in any case, be held liable for any direct or indirect damages resulting from the failure of the air conditioner. The warranty is exclusively limited to the product itself.



The European Community attaching a great importance to the environment and the waste processing, set up Directive 2002/96/CE relating to the Electric and Electronic Component waste.

In accordance with this standard, the logo "barred dust bin" is obligatory.

This logo means that this product cannot be thrown in the household shelter. It must be given to a suitable collection point for the treatment, valorisation, recycling of Electric and Electronic components.

Acting like that you make a gesture for the environment and you contribute to the safeguarding of the natural resources as well as to the protection of human health.