



Aster Filter

- ✓ Sand filter, laminated with polyester / fibre glass resin
- ✓ Equipped with collectors of 1" diameter and diffuser of highly resistant PVC
- ✓ Side mount 6 way multi port valve



Aster Filter

Aster laminated sand filters are known for their reliability, making them one of the top selling filters in the world, as well as for their collector arms, which feature a larger diameter for greater filtering surface. Fitted with an

AstralPool multiport valve with 6+1 positions for filter, backwash, rinse, recirculating, waste and closed. A patented system is used for opening and closing the cover, thereby eliminating the use of traditional screws.



SPECIFICATIONS

	Aster Filter D 600	Aster Filter D 750
D mm	600	750
H mm	850	945
M mm	455	555
N mm	330	325
Connections	1 1/2"	2
Flow m3/h a 50m3/h/m2	14	21
Pool (volume) m3	112	168
Sand / Gavel kg	125	210
Maximum working pressure kPa	2.5	2.5
Viron Glass Coarse	2 bags	4 bags
Viron Glass Fine	5 bags	7 bags

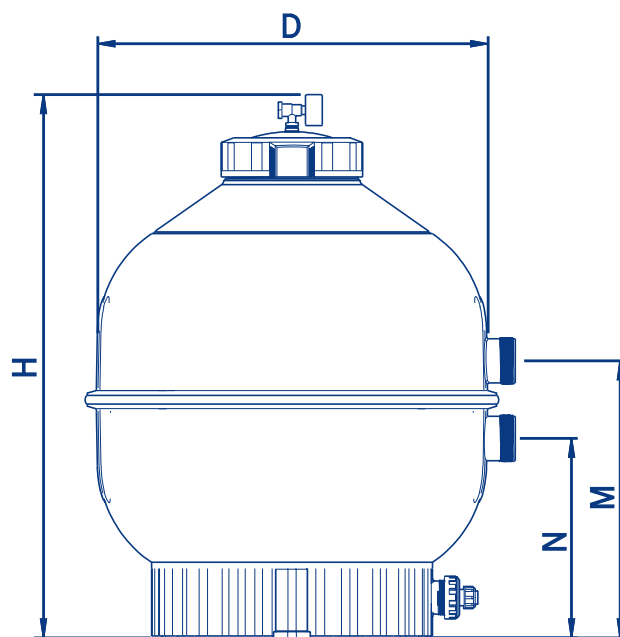

Available from:



A division of
FLUIDRA

Melbourne: 03 8796 8600 Gold Coast: 07 5552 2600
 Sydney Seven Hills: 02 9853 2100 Townsville: 07 4796 0100
 Sydney Moorebank: 02 8778 9500 Adelaide: 08 8152 7600
 Brisbane: 07 3308 5400 Perth: 08 9350 2600

sales@astralpool.com.au
 www.astralpool.com.au

 facebook.com/astralpoolAU

ASTRALPOOL 

BX **POOL & SPA PUMP**

- ✓ High flow, high pressure performance
- ✓ Huge basket reduces maintenance
- ✓ Robust and reliable construction
- ✓ 3 year warranty



BX POOL & SPA PUMP



The demands on pool equipment in modern pools like large in-ground pools, swim spas, swim jets, larger pool filters, salt-chlorinators and in floor cleaning system place an enormous load on the pump.



RELIABLE STRENGTH

The BX Series pump has been designed with great power and control to comfortably meet these demands by delivering a much higher head pressure and a superior overall performance. With reliable external body and high quality components this pump has the highest standards of reliability and durability.



SAME POWER, LESS ENERGY

While meeting the demands of your equipment the BX also moves more water, using less power in fewer hours per day. This means lower electricity costs. With a huge hair and lint pot the BX requires less frequent cleaning, making it ideal for holiday home and high leaf areas.



SUPERB SILENCE

In high density residential area, noise is an issue so the BX pump has been designed to run cooler with less fan noise which means reduced noise level.



WARRANTY

Available in 4 different sizes and covered by a limited 3 year warranty against defects in materials and workmanship the BX-Series pool and spa pump is the perfect choice for your pool.

To find out more about the BX-Series pump visit astralpool.com.au

TECHNICAL INFORMATION

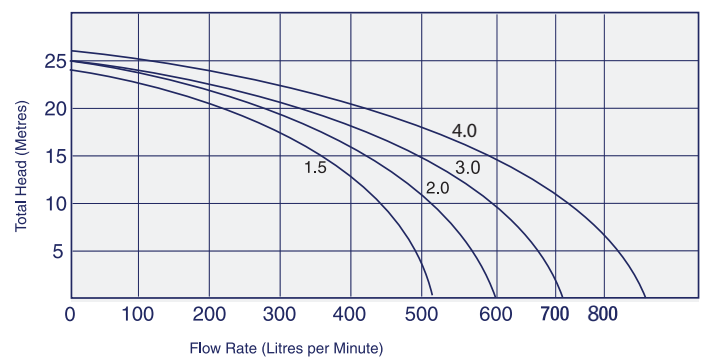
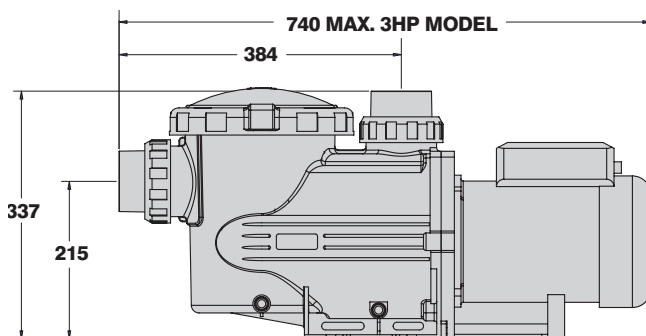

Model	Volts	Phase	Input Watts	Full Load Amps	Flow Rate Max @ 8 m/h	Conns "mm"
BX 1.5 HP Pool & Spa Pump	240	Single	1645	7.2	440 lpm	65/50
BX 2.0 HP Pool & Spa Pump	240	Single	2030	8.8	540 lpm	65/50
BX 3.0 HP Pool & Spa Pump	240	Single	2300	12.5	640 lpm	65/50
BX 2.0 HP Pool & Spa Pump 3 Phase	415	Three	2195	3.4	540 lpm	65/50
BX 3.0 HP Pool & Spa Pump 3 Phase	415	Three	2650	4.1	640 lpm	65/50
BX 4.0 HP Pool & Spa Pump 3 Phase	415	Three	2985	4.7	750 lpm	80



sales@astralpool.com.au

www.astralpool.com.au

[facebook.com/astralpoolAU](https://www.facebook.com/astralpoolAU)



RolaChem Chemical Dosing RC1

- ✓ Save up to 30% on chemical costs
- ✓ Reduce pool maintenance time
- ✓ Adjusts liquid sanitiser amounts automatically
- ✓ One year warranty



RolaChem Chemical Dosing

To keep your pool algae and bacteria free doesn't have to be a daily task.

By using the RolaChem RC1 Chemical Dosing System, accurate amounts of chlorine (any liquid sanitiser) or liquid pH adjuster can be selected and adjusted to automatically dose your pool or spa as required to maintain clean, healthy and balanced water.

The gradual dosing of sanitiser and pH adjuster significantly reduces your chemical usage and saves you as much as 30% of your chemical costs by minimising fluctuating levels of chemicals. The RC1 removes the daily need of adding chemicals and much of the guess work in pool or spa ownership. Slow and constant addition of your chemicals creates a healthy pool or spa, reduces time and saves you money in maintaining your pool.

Simple and easy to install the RC-1 is available with various metered pump sizes to handle small spa pools up to commercial or resort sized swimming pools.

The RC-1 is covered by a one year warranty against defects and faulty manufacturing. Refer to the product instructions at astralpool.com.au for full warranty details.

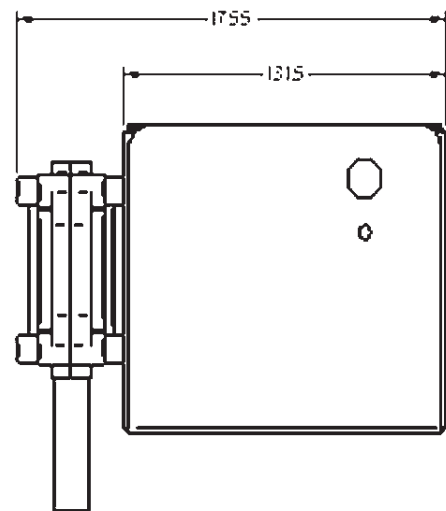
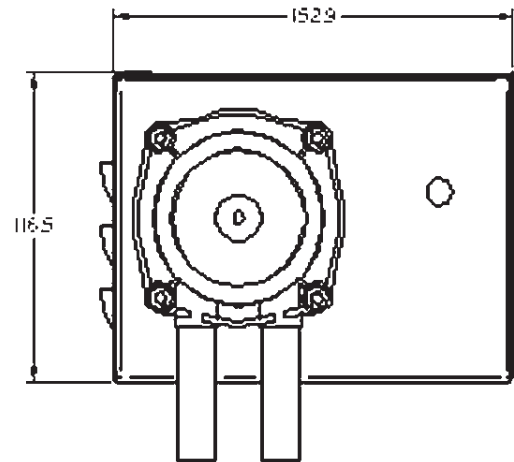

SPECIFICATIONS

pH DOSING

Model	Litres of pH adjuster per hour	Max RPM for a pH adjuster Pump	Pool Size (Litres)
RC1 0/1	0.02-0.2	1	80,000
RC1 0/5	0.1-0.9	5	240,000
RC1 0/20	0.8-3.0	20	750,000

SANITISER DOSING

Model	Litres of sanitiser per hour	Max RPM for a sanitiser Pump	Pool Size (Litres)
RC1 5/0	0.1-0.9	5	80,000
RC1 20/1	0.8-3.0	20	240,000
RC1 100/0	3.0-15	100	750,000

Available from:



A DIVISION OF
FLUIDRA

Melbourne: 03 8796 8600 Gold Coast: 07 5552 2600
 Sydney Seven Hills: 02 9853 2100 Townsville: 07 4796 0100
 Sydney Moorebank: 02 8778 9500 Adelaide: 08 8152 7600
 Brisbane: 07 3308 5400 Perth: 08 9350 2600

sales@astralpool.com.au
www.astralpool.com.au



facebook.com/astralpoolAU



VIRON EQ SALT CHLORINATOR WITH BLUETOOTH

WARNING

FOR YOUR SAFETY - This product must be installed and serviced by a licensed electrician in accordance with the latest, enforced version of AS/NZS 3000 and any other local applicable regulations. Before installing this product, read and follow all warning notices and instructions that accompany this product. Failure to follow warning notices and instructions may result in property damage, personal injury, or death. Improper installation and/or operation will void the warranty.

Improper installation and/or operation can create unwanted electrical hazard which can cause serious injury, property damage, or death.

EQUIPMENT INFORMATION RECORD

DATE OF INSTALLATION _____

INSTALLER INFORMATION _____

INITIAL PRESSURE GAUGE READING
(WITH CLEAN FILTER) _____

PUMP MODEL _____

HORSEPOWER _____

FILTER MODEL _____

CONTROL PANEL MODEL _____

SERIAL NUMBER _____

TABLE OF CONTENTS

Section 1. Important Safety Instructions	4	Section 7. Pool Chemistry and Balance	14
Section 2. System Overview	6	7.1 pH Regulation Principle	14
2.1 Overview	6	7.2 Chlorine Output and Filtration Time	14
2.2 Contents	6	7.3 Water Chemistry	15
2.3 Specifications.....	6	7.4 Chlorine Dosing and ORP.....	17
Section 3. Installation.....	6	Section 8. Maintenance.....	17
3.1 Controller Location.....	6	8.1 Regular Scheduled Maintenance	17
3.2 Mounting the Controller.....	7	8.2 Lubricate the Acid Pump Squeeze Tube	18
3.3 Connecting the PVC Acid Tube	8	8.3 Clean and Calibrate Sensors.....	18
3.4 pH Sensor (optional, part no. 525147).....	9	Section 9. Ai Mode	18
3.5 Chlorine Sensor (optional, part no. 525145)	9	9.1 Ai Equipment Requirements.....	18
Section 4. Chlorinator Setup.....	9	9.2 Ai Mode Connection	19
4.1 Initial Startup	10	9.3 Ai Mode Set Up	19
4.2 Backwash the Filter.....	10	9.4 Operation in Ai Mode.	19
4.3 Set Dosing.....	10	9.5 Ai Mode Timers	19
4.4 Acid Dosing	11	9.6 Effects of Ai Mode	19
Section 5. Day to Day Operation.....	12	Section 10. Troubleshooting.....	21
5.1 Set the Clock	12	Section 11. Exploded Diagram	
5.2 Set Timers.....	12	and Parts List	22
5.3 Adjust Chlorine Output.....	13	Section 13. Warranty	23
5.4 Adjust pH Setpoint	13	13.1 Warranty Terms	23
Section 6. Bluetooth Setup	13	13.2 Consumer Information and Safety.....	23
6.1 Connect via Bluetooth.....	13		
6.2 Install the App	13		
6.3 Pair the Chlorinator	13		
6.4 Basic App Functions	14		

Section 1. Important Safety Instructions

READ AND FOLLOW ALL INSTRUCTIONS

All electrical work must be performed by a licensed electrician and conform to all national, state, and local codes. When installing and using this electrical equipment, basic safety precautions should always be followed, including the following:

⚠ DANGER

To reduce the risk of severe injury or death, do not remove the suction fittings of your spa or hot tub. Never operate a spa or hot tub if the suction fittings are broken or missing. Never replace a suction fitting with one rated less than the flow rate marked on the equipment assembly.

⚠ WARNING

Prolonged immersion in hot water may induce hyperthermia. Hyperthermia occurs when the internal temperature of the body reaches a level several degrees above the normal body temperature of 37°C. The symptoms of hyperthermia include dizziness, fainting, drowsiness, lethargy, and an increase in the internal temperature of the body. The effects of hyperthermia include: 1) unawareness of impending danger; 2) failure to perceive heat; 3) failure to recognize the need to exit spa; 4) physical inability to exit spa; 5) fetal damage in pregnant women; 6) unconsciousness resulting in a danger of drowning.

⚠ WARNING

To Reduce the Risk of Injury -

- a) The water in a spa should never exceed 40°C. Water temperatures should remain between 38°C and 40°C. The water in a spa should never exceed 40°C. Water temperatures between 38°C and 40°C are considered safe for a healthy adult. Lower water temperatures are recommended for young children and when spa use exceeds 10 minutes.
- b) Since excessive water temperatures have a high potential for causing fetal damage during the early months of pregnancy, pregnant or possibly pregnant women should limit spa water temperatures to 38°C. Before entering a spa or hot tub, the user should measure the water temperature with an accurate thermometer since the tolerance of water temperature-regulating devices varies.
- d) The use of alcohol, drugs, or medication before or during spa or hot tub use may lead to unconsciousness with the possibility of drowning.
- e) Obese persons and persons with a history of heart disease, low or high blood pressure, circulatory system problems, or diabetes should consult a physician before using a spa.
- f) Persons using medication should consult a physician before using a spa or hot tub since some medication may induce drowsiness while other medication may affect heart rate, blood pressure, and circulation.

⚠ WARNING

Risk of electric shock - Install at least 3.5 metres from the inside wall of the pool and/or hot tub using non-metallic plumbing.

Do not use spas or hot tubs unless all suction guards are installed to prevent body and hair entrapment.

People using medications and/or having an adverse medical history should consult a physician before using a spa or hot tub.

This product is NOT suitable for use on Spa Pools UNLESS the OPTIONAL pH sensor has been purchased and installed.

When used on Spa Pool applications, AstralPool strongly recommend the purchase and installation of a chlorine sensor in addition to the pH sensor.

This product is NOT suitable for use on Indoor swimming pools UNLESS the pH and Chlorine sensors have been purchased and installed.

Take extreme care when handling the pH adjuster which is either sulphuric acid or hydrochloric acid. Wear gloves, eye protection and breathing protection.

⚠ WARNING

People with infectious diseases should not use a spa or hot tub.

Children should not use spas or hot tubs without adult supervision.

To avoid injury, exercise care when entering or exiting the spa or hot tub.

Do not use drugs or alcohol before or during the use of a spa or hot tub to avoid unconsciousness and possible drowning.

Before entering a spa or hot tub, measure the water temperature with an accurate thermometer.

Do not use a spa or hot tub immediately following strenuous exercise.

Prolonged immersion in a spa or hot tub may be injurious to your health.

Do not permit any electric appliance (such as a light, telephone, radio, or television) within 3.5 metres of a spa or hot tub.

The use of alcohol, drugs or medication can greatly increase the risk of fatal hyperthermia in hot tubs and spas.

Water temperature in excess of 38°C may be hazardous to your health.

⚠ WARNING

A terminal bar marked "GROUND" is provided within the controller. To reduce the risk of electrical shock which can cause serious injury or death, connect this terminal bar to the grounding terminal of your electric service or supply panel with a continuous copper conductor having green insulation and one that is equivalent in size to the circuit conductors supplying this equipment in accordance with the latest, enforced version of AS/NZS 3000. In addition, where required, bonding should be extended in accordance with the latest, enforced version of AS/NZS 3000 to any metal ladders, water pipes, or other metal within 3.5 m of the pool/spa.

CAUTION

Dose pool with a small amount of chlorine before starting the eQ. If no chlorine is sensed the eQ may go to fail safe mode and not start up. Some Chlorine should be present before starting the unit.

Before installing probes, balance pool water. Total Alkalinity (TA) must be 80 to 120 ppm, Calcium Hardness should be 180 to 250 ppm, and pH must be between 7.2 and 7.6.

Cyanuric Acid, sometimes referred to as stabiliser or sunscreen will suppress the Chlorine (ORP) reading when the Chlorine sensor is connected. Refer to section on setting chlorine levels if Cyanuric Acid is present in your pool.

Product is designed to run with ACID diluted to water to acid ratio of 2:1 should always be followed as the machines dosing rate is formulated around the diluted solution. Using neat acid can lead to overdosing the pH level.



Attention Installer: Install to provide drainage of compartment for electrical components.

SAVE THESE INSTRUCTIONS

Section 2. System Overview

2.1 Overview

The Viron e-Quilibrium Chlorinator incorporates a controller with inbuilt acid pump, an electrode cell for converting minerals or salts into chlorine, a mounting plate for the controller and tubes, and injection points for the acid which controls your pool water pH. The intelligent software allows you to select and change your acid dosing ratio and intelligently adjusts the dose rate to match the output of the electrode. (The higher the output, the faster the pH will change and the more the controller will dose acid to compensate). However, you MUST test your pH every day for the first week and adjust your acid dose rate on the controller to achieve the correct pH level.

2.1.1 pH Levels

Generally you should aim to have your pH at 7.4 to 7.8. The actual pH you choose for your pool will depend on the water quality in your area, the interior finish of your pool and the type of pool you have.

2.2 Contents

Before starting, check that you have the correct parts as indicated in Figure 1 and Table 1. If any parts are missing or incorrect, please call your local distributor or technical support at 1300 763 021 for assistance.

2.2.1 Viron e-Quilibrium Basic Chlorinator System



Figure 1. Chlorinator System Contents

Components	
a.	eQ Controller
b.	Controller Mounting Plate
c.	Chlorinator Cell and Electrodes
d.	Screws for Mounting Plate
e.	50mm Injection Mixing Cell
f.	50mm unions for glue-in pipe connection
g.	PVC Tube Acid Drum Connection and Venting Kit

Table 1. Chlorinator System Contents

2.3 Specifications

2.3.1 Salt Chlorinator System

	Compact	Mid	Large
Nominal chlorine production	18 g/h	25 g/h	35 g/h
Nominal output amps	3.6 A	5.0 A	7.2 A
Required salt level	4000ppm		
Power supply voltage	240 VAC - 50 Hz		
Electric power	200 W		
Protection index	IP43		
Flow through the cell	Min. 80 Lpm		
Max pressure in the cell	2.75 bar		
Operating water temperature	10°C - 40°C		

Table 2. Salt Chlorinator System Specifications

Section 3. Installation

3.1 Controller Location

The controller should be located at or near the equipment pad, at least 3.5 metres or more away from the inside wall of the pool/spa, 1.5 metres off the ground, and within 2 meters of the cell. All national, state, and local codes are applicable.



Figure 2. Equipment Configuration, Acid Dosing



Figure 3. Equipment Configuration, Acid Dosing and Optional Sensor Probes

Choose a location that is preferably out of direct sunlight, near the filter system. The controller should be located 1 metre above ground level to prevent rain splash back or sprinkler system damage to the underside of the controller. The controller must be mounted on a vertical surface/wall. If mounted on a post, a flat sheet 20mm larger than the controller housing must be used.

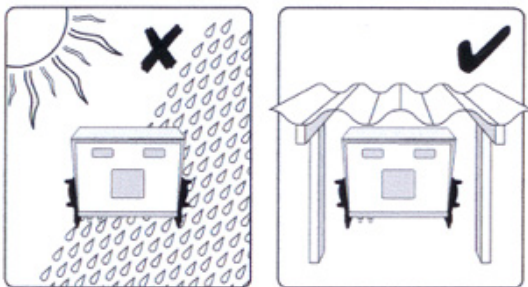

Figure 4. Correct Installation Location

3.2 Mounting the Controller

⚠ WARNING

- The cell must be installed horizontally and level. Improper installation can lead to gas build up which could result in equipment damage or serious injury.
- The cell must be the last piece of equipment on the return line.
- It is recommended in all installations that the cell is installed on a bypass equipped with isolation valves.
- In order to avoid load loss, installing the cell on a bypass is MANDATORY if system flow rated exceeds 300 Lpm.
- If installing on a bypass, use a downstream check valve instead of a manual valve to prevent improper back flow into the cell.

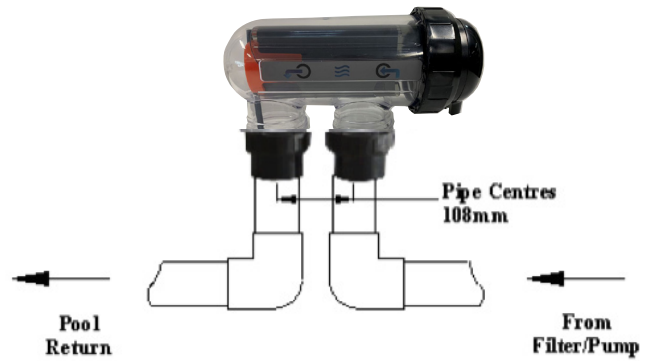

Figure 5. Correct Cell Installation

Before installing the unit in position on the wall or post, the length of the PVC tubing provided should be measured and taken into consideration. Ensure the controller and cell are close enough for the power supply lead to reach the cell and sufficient PVC tube exists to connect acid container and cell.

1. Mount the wall bracket using the screws provided on a secure wall.
2. Glue sensing chamber for probe into plumbing line after filter and gas heater (if installed) but prior to chlorinator cell. Sensor Chamber must be plumbed to ensure probe is horizontal to water flow.
3. Glue Chlorinator cell into line as per drawing below after filter, heater, solar (if installed) and after sensor T piece.
4. Plug the pH sensor into the underside of the controller in the location marked "pH".
5. Plug filter pump 3 pin plug into underside of Controller.
6. Connect 4 wire cell cable ensuring matching colours.
7. Remove cap from pH sensor and screw firmly into sensor chamber installed in the plumbing. Do Not Over tighten.
8. The cell must be installed with the barrel unions underneath and the cell should be horizontal. Both 40mm and 50mm fittings have been provided. Make sure that the o-rings are correctly fitted and the unions are done up tightly.

NOTE: Direction of water flow through the cell is critical – refer to label on the controller housing.

9. Hang the controller on wall bracket and plug power supply lead into 3 pin 10 amp outlet.

3.3 Connecting the PVC Acid Tube

3.3.1 Placement of Chemicals

⚠ WARNING

- Never mix chemicals
- Chemicals must be stored in accordance with Relevant Standards and Dangerous Goods Codes. Consult your authorized builder or pool shop technician for advice.
- When handling acid, safety gloves and goggles should always be used.
- Chemicals must be at least 1 metre horizontally from control unit in a well ventilated area to avoid corrosive damage.
- For best results a ratio of 2:1 is recommended.

Consult your authorized builder or pool shop technician for additional advice as needed.



Figure 6. Acid Container Installed

3.3.2 EQ Line Connections

The unit is designed to run with 2 PARTS WATER, 1 PART ACID (2.1 RATIO). Proper ratio should always be followed as the machines dosing rate is formulated around the diluted solution. Using neat acid can lead to overdosing the pH level.

NOTE: When installing acid container in a filter enclosure, which has no ventilation, it is recommended that the hole in the cap of the container is cut or drilled to fit tightly around the tubing, so that fumes from the acid will not corrode the equipment. It will be necessary to drill a second hole in the cap fitted tightly with a length of tubing which should then be vented outside the filter enclosure. This procedure is recommended only where the filter enclosure has no ventilation and is to protect the equipment.

3.3.3 Install the PVC Tube

To avoid loss of water from the system, close all stop valves before cutting any lines.

- Clear Tube - 4m to be cut to required length (installation dependant)
- White Tube -to be inserted in the Container lid (2 lids are supplied with the kit to suit either a 25/15 ltr or a 5 ltr container) The tube is supplied to suit to a length to suit a 25ltr container. For use on 15 ltr containers, the white tube needs to be cut to approx. 265mm long. For use on 5 ltr containers the white tube needs to be cut to approx. 250mm long.

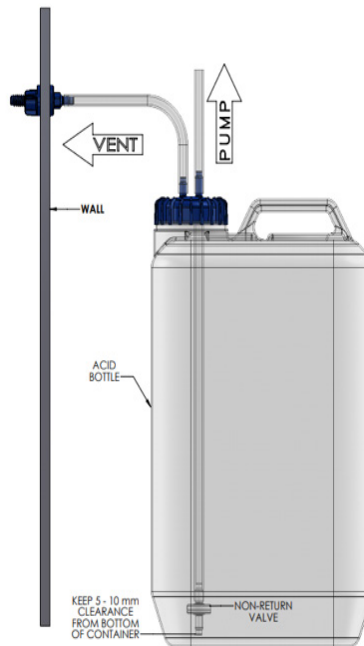

Figure 7. Acid Container Line Connections

For both applications, ensure the non return valve is inserted into the tube. Ensure it is fitted in correctly, when fitted correctly you should be able to blow through the valve into the tube.

1. Thread the clear PVC tube through a hole in the cap or shoulder of the chemical container.
2. Ensure that the non-return valve is fitted correctly.
3. The clear PVC tube should fit snugly in the hole in the cap or shoulder of the chemical container.

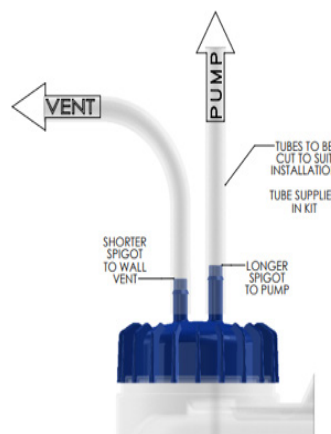

Figure 8. Acid Cap Tube Fitting and Venting

4. Make a small 2mm breather hole in the cap to allow air to fill the void created by the acid.
5. Connect the other end of the PVC tube to the inlet of the acid pump on the front of the controller.
6. Connect the remaining hose to the outlet of the acid pump on the underside of the controller.
7. Thread the remaining end of the PVC hose through the cable gland in the 50mm PVC mixing cell fitting so that it passes through the cable gland by 25mm to 30mm.
8. Position the injection chamber in a horizontal position after the Chlorinator cell on the return to pool side.

TIP: Soaking the ends of the PVC tubing in hot water or gently heating with a lighter will make it easier to push onto the barb.

3.4 pH Sensor (optional, part no. 525147)

An optional pH sensor eliminates the need to regularly test your pH balance of your pool and spa. The sensor must be checked and recalibrated every 6 months.

When installed and connected, the Viron e-Quilibrium will automatically detect the pH sensor and the factory pH setpoint is 7.6. You can adjust your ideal pH setting in the Settings menu.

3.4.1 Connect the pH Sensor

The pH sensor is supplied with a sensor chamber that is connected into 50mm PVC pipe work using 50mm union tails and lock nuts.

1. Install the sensor chamber vertically, where possible after the filter and before the chlorinator cell.
2. Glue in 50mm PVC pipe into union tails.
3. Remove rubber boot from pH sensor and screw into the sensor chamber port.
4. Blank off the remaining ports in the sensor chamber using the caps and gaskets supplied.

3.5 Chlorine Sensor (optional, part no. 525145)

An optional chlorine sensor allows the Viron e-Quilibrium to automatically control the chlorine and pH levels of your pool and spa water. A chlorine sensor is highly recommended for pool and spa combinations, spa pools and indoor pools and spas.

The Chlorine Sensor uses Oxidation Reduction Potential (ORP) readings to determine the chlorine level in your pool or spa water. ORP is the most reliable and safest way to determine the level of the sanitiser in your water but is affected by other factors influencing the efficiency of the chlorine. Water pH, the use of sunscreens (cyanuric acid), Hardness and other items can all influence the reading of the ORP

The Viron e-Quilibrium will adjust the production of chlorine to meet the ORP which may mean the chlorine level, when measured in simple PPM (parts per million) levels may change from time to time. This is normal. An example of higher chlorine readings when measured in ppm is if the acid runs out and is not replaced. In this case, the pH will start to increase and the effectiveness of the chlorine will reduce. As the chlorine effectiveness reduces the ORP measurement declines and the Viron e-Quilibrium will increase the power to the electrode cell to produce more chlorine. Once the pH level is corrected the Viron e-Quilibrium will reduce or turn off the power to the electrode cell as the ORP reading will rise.

Once connected, the e-Quilibrium will automatically detect the sensor and a factory pre-set chlorine level of 600 mv will be maintained.

3.5.1 Connect the Chlorine Sensor

The chlorine sensor is provided with a 3 metre RJ12 cable for connection to a Viron variable speed energy efficient pump.

1. Screw the chlorine sensor into the pH sensing chamber connected to the bottom of the Viron e-Quilibrium controller.
2. Install the sensor chamber vertically, where possible after the filter and before the chlorinator cell.

NOTE: The sensor chamber must have the acid dosing point installed away from the chlorine and pH sensors. Make sure the acid dosing point is after the chlorinator cell and the chlorine and pH sensors are before the chlorinator cell.

3. Remove rubber boot from the chlorine sensor and screw into the sensor chamber port (glued into pipework either before filter or between filter and Chlorinator cell).

Section 4. Chlorinator Setup

The Chlorinator can be controlled using the screen and buttons or via an App on a compatible smartphone or tablet using Bluetooth.

Initial set up for equipment such as variable speed pumps etc, needs to be performed using the Chlorinators screen and buttons. After initial setup, most other functions can be performed using either the Chlorinator or the App.

Chlorinator basic functions are:

- Maintenance – special functions and initial set up to suit your pool and spa.
- Setting – adjust chlorine production and pH of pool and spa water.
- Clock and Timer – set current time and timers for filtration, chlorine production and pH monitoring.
- Pool and Spa Mode – select mode specific to producing chlorine and acid dosing either the pool or the spa

4.1 Initial Startup

Press MAINT from the Chlorinator menu to access startup functions.

- From MAINT press NEXT, NEXT
- Choose INSTALL.

4.1.1 Select Language

Select INSTALL from the Maintenance menu and you ACCEPT the appropriate Language for your Chlorinator (English is the default language). INSTALL CHLORINATOR is displayed.

4.1.2 Chlorinator Installation Settings

After setting the Language option, you will be asked if you want to INSTALL CHLORINATOR.

Set the following install options:

- TIMER ENABLED – Turn your timer on or off. Press ACCEPT. If the chlorinator is connected to an external timer clock or Genus Remote Control system choose Disable.
- FAST COMMS – Do not change this function unless you are using an older version Hurlcon/AstralPool controller (no touchscreen).
- VARIABLE SPEED PUMP – Program the speed of the pump as part of the timer setting in the chlorinator. Choose YES if you have an AstralPool 3 speed pump.
- FLUSH AFTER TIMER – Turn on pump will momentarily after timed cycle to flush residual chemicals from the injection chamber.
- PUMP FLOW CHECK – Monitor the flow sensor inside the chlorinator cell. If water flow is not detected for over 5 minutes, power to the pump outlet will be shut down to prevent damage to the pump.
- ENABLE LIGHT – Set your Chlorinator to control a Connect LITE lighting controller (SLX setting)
NOTE: If an SLX light is connected via the ARC setting, there is no way to control colour other than with On/Off to cycle through the colours. Colour is not saved for next use and reverts to white.
- CELL REVERSAL PERIOD – Do not change this setting without consulting with your local AstralPool dealer or service department. Standard setting is 4 hours.
- REVERSE CELL? – Perform a manual reverse of your chlorinator cell – designed for use by your pool technician only.
- SET POOL WATER VOLUME – Change the volume of your pool. Select YES and use up/down arrows to change. Press ACCEPT.
NOTE: Setting is only available if probes are installed.

- SET SPA WATER VOLUME – Change the volume if you have a spa attached to your pool. Select YES and use up/down arrows to change. Press ACCEPT.
NOTE: Setting is only available if probes are installed
- RESET SYSTEM? – Revert the Chlorinator back to factory settings. Select NO. Use only in the case of a system error that can't be cleared.

4.1.3 Set Auto Operation Schedule

Cycle through POOL MODE button to select Auto, Manually ON or Manually OFF.

AUTO will allow the unit to operate your filter pump, chlorine production and pH adjustment on the timer periods you have selected. If you have not changed the timer periods, the default timer turns the filter pump and unit on at 08:00 hours for a period of 4 hours and then again at 16:00 hours for a further period of 4 hours. This is the default setting from the factory.

4.2 Backwash the Filter

Before running the Chlorinator for the first time, ensure your sand filter is backwashed for 2 to 3 minutes and then rinsed for 1 minute.

- Turn pump off when changing the position of the backwash valve on your filter.
- Press MAINT
- Press BACKWASH and the up or down arrows to choose the backwash time duration.
- To rinse the filter, select BACKWASH again and select the time duration.

NOTE: You can press ABORT at any time to stop the backwash cycle.

4.3 Set Dosing

Set the Acid dosing time and amount via the DOSE function or override the time clock to set the Chlorinator to allow for additional circulation of the swimming pool water after treatment or cleaning.

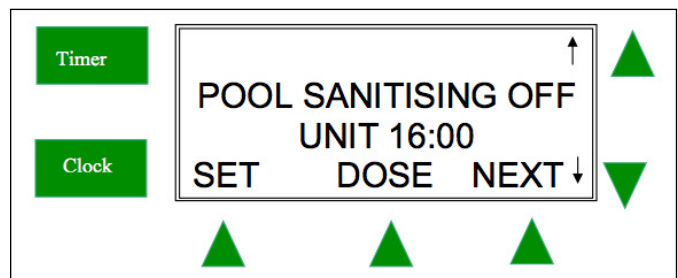

Figure 9. Chlorinator menu screen - Dose

Press DOSE and up/down arrows to:

- a. Shock Chlorinate the Pool: Provide a shock dose of chlorine production or sanitise until the first timer tomorrow morning.
- b. Manually prime Acid Pump: Select this function to fill the clear PVC tube with Acid on initial start-up or after changing or refilling the Acid Container. The priming period is for 300 seconds but can be stopped at any time. If the tube is not completely filled with Acid after 300 seconds repeat the process.
- c. Manually Dose Acid: Select this function to manually dose acid for a predetermined time.

4.4 Acid Dosing

Your pool professional may recommend the addition of Acid to your pool.

To manually dose the pool:

1. Press the up/down arrows to select the quantity of acid in litres.
2. Press ACCEPT.

⚠ WARNING

- Hydrochloric Acid should be handled with extreme care.
 - Refer to Material Safety Data Sheets on Hydrochloric Acid.
 - Do not inhale Acid fumes.
 - Do not spill.
 - Handle with extreme care during transport.
 - Use protective gloves and goggles
 - In the case of spillage wash down with fresh water immediately.
 - Keep out of reach of children.
3. Choose the mode to revert to following completion of Acid dosing: AUTO, ON or OFF
 4. Choose AUTO for normal operation. This puts the unit back into time clock operation.

4.4.1 Acid Dosing without Sensors

The base model Viron e-Equilibrium is supplied without any pH or Chlorine sensors (sensors can be ordered separately). In this model, you can determine the dosing rate of the acid by selecting 1 to 10 in the pH set screen.

The Chlorinator will adjust the dosing level according to the chlorine production (the higher the chlorine production, the faster the pH change and the more acid required).

1. Install the acid dosing tube after the chlorinator cell on the return to the pool pipe.
2. Once the pH value is set, the information screen will alternate between the current status of the chlorinator and the chlorine output setting (between 0 and 8).

IMPORTANT: Check the pH balance each day for the first week of operation. Adjust the pH setting until it settles at the desired pH level. Once the desired pH level is achieved, continue to manually test your pH every week and adjust the pH setting as required.

4.4.2 Acid Dosing with Sensors

When pH and chlorine sensors are connected, the screen displays the following messages:

- Chlorine Level (chlorine low, chlorine OK, chlorine high)
- Cell operating at (percentage of maximum output, or "off")
- pH set point (factory preset at 7.6)
- pH actual (will read close to set point providing acid container has acid available to be dosed)
- ORP levels (commercial applications only). Use the up/down arrows to change the default to YES from the following screen to display actual ORP levels.

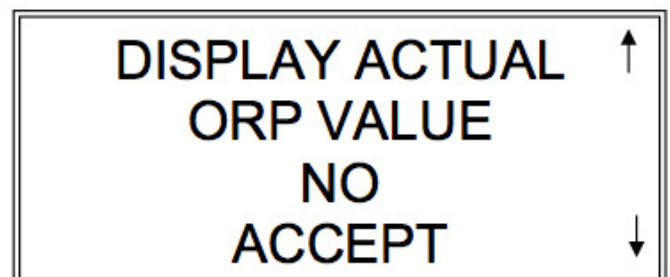

Figure 10. Display Actual ORP screen

CAUTION

ORP readings can vary when the filter pump is off and also if Cyanuric Acid is present in the water. Daylight hours show a reduced ORP, while at nighttime, the Cyanuric Acid detaches from the chlorine molecule which increases the ORP reading. ORP readings should only be recognised while the pump is operating and during daylight hours.

Section 5. Day to Day Operation

For regular operation, make adjustments via the SET button on the Chlorinator.



Figure 11. Chlorinator screen - SET button

5.1 Set the Clock

The clock is a 24 hour clock. Set the current day and time before setting system timers.

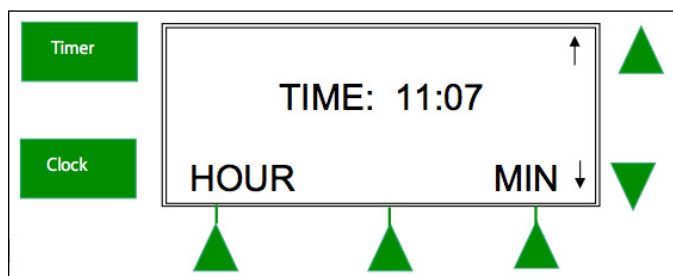

Figure 12. Set day of the week and time

1. Press "Pool Mode" button until Manually Off is displayed.
2. Press the Clock button
3. Select Day.
4. Use up/down buttons to set the current day, hour and minute.

5.2 Set Timers

The Chlorinator has up to four timers per day enabling you to set different periods in which your filtration pump, pH control and chlorine production will operate. If Lighting has been enabled in the INSTALL menu, there are also two separate light timers that can be set up in addition to the four filter timers. To set timers, do the following:

1. Press the TIMER button.
2. Press HOUR button to set the hour for the timer selected
3. Use the Up/Down arrows to change the Start time.
4. Press MIN button to select the minutes for the timer selected.
5. Use the Up/Down arrows to change the Start time.
6. Press the NEXT button to set the RUN time.

NOTE: For light timers to work, the chlorinator and lights must both be set to Auto mode. Light timers will not work if the chlorinator is set to Off or Manual. Even if the light is set to Auto, this function is ignored and the lights will not come on automatically.

7. Press the NEXT button to return to normal display and save new settings.

5.2.1 Auto Sanitising

AUTO mode sets the controller on timer clock mode. In AUTO mode the LCD screen will display the date and pool sanitiser or light message.

1. Press the POOL mode button.
2. Scroll through settings and select AUTO.

5.2.2 Lighting Timers

You can set additional lighting timers to control lights automatically. Use either use the Connect LITE remote control, or the LIGHT button on the chlorinator to set a timer for the Lights to AUTO.

5.2.3 Timer Recommendations

Generally, you should operate your pool pump for 8 hours a day in total to achieve sufficient chlorine production and circulate the pool water including skimming which will reduce debris settling in the pool and ongoing maintenance.

As a default, the control is set to come on at 08:00 hours and 16:00 hours both for periods of 4 hours.

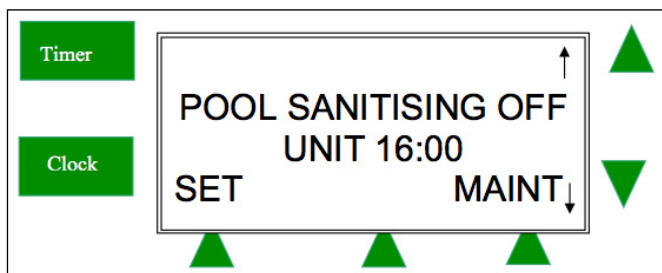

Figure 13. Timer Default On/Off settings

Recommendations for timers:

- Two timers: one for morning, one for the evening sanitizing cycle
- Timers should typically run for periods of 2-5 hours each.
- A third timer can be used for lighting with the pump off.
- Chlorinator is most effective if run in the early morning or evening when it is cooler (strong sunlight consumes more chlorine)

5.3 Adjust Chlorine Output

In summer (or other heavy bathing times), chlorine output should be set between 6 and 8. Check chlorine level in your swimming pool regularly to determine if the output should be increased or decreased. Rely on a pool professional for additional advice on the recommended chlorine level in your pool.

Free chlorine level should be between 1.0 ppm and 3.0 ppm.

1. Press SET to change the chlorine output and the pH of your pool.
2. Press YES to change the setting.

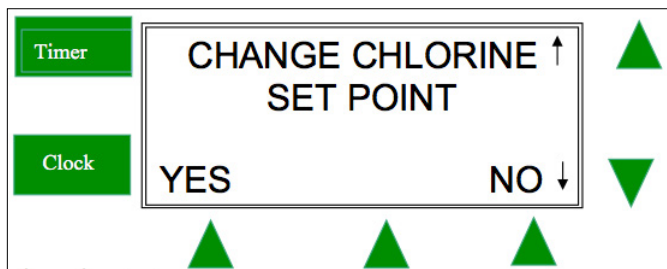

Figure 14. Change Chlorine Set Point

3. Use up/down buttons to change the Set Point between 0 and 8 pH.

NOTE: 0 chlorine output should only be used when there is no salt in the water.

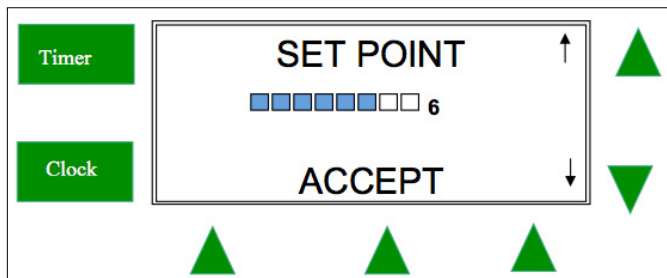

Figure 15. Choose Set Point

5.4 Adjust pH Setpoint

pH in your pool should be set between 7.4 and 7.8. Variations are determined by the type of pool you have (concrete, fibreglass, vinyl liner). Rely on a pool professional for additional advice on the correct pH Set Point for your pool.

1. Press SET to change the pH balance of your pool.
2. Use up/down buttons to set your pH value.

Section 6. Bluetooth Setup

6.1 Connect via Bluetooth

The INSTALL function allows the unit to be set up for your pool or spa and to pair your phone with the Chlorinators Bluetooth connection.

1. From MAINT press NEXT, NEXT
2. Choose INSTALL.
3. ACCEPT the current Language. INSTALL CHLORINATOR is displayed.
4. Press NEXT, NEXT. INSTALL BLUETOOTH is displayed.
5. Press ACCEPT. A 4 digit BLUETOOTH ACCESS CODE is displayed.

Keep this unique code to enter into the ChlorinatorGo App and set up your chlorinator in the App.

6.2 Install the App

Download the ChlorinatorGo App from either the Apple App Store or Google Play.

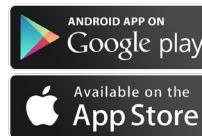

From the App:

1. Press +
2. Enter your 4-digit ACCESS CODE .
3. Press from above and press Save.
4. Type a name for your Chlorinator.

6.3 Pair the Chlorinator

From the App:

1. Choose the name of your chlorinator.
2. Your phone will connect to the chlorinator.
3. The App Home Page is displayed.

6.4 Basic App Functions

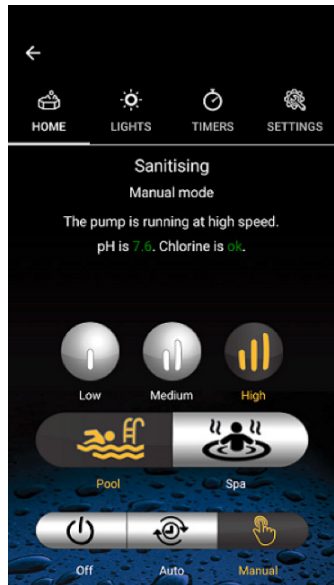

Figure 16. ChlorinatorGo App - Home Page

Functions available from the App are:

- Chlorinator - set On, Off, Auto
- Pool or Spa Mode
- Set pump speed (if a compatible AstralPool pump is installed)
- pH and ORP readings (if pH and ORP probes are fitted)
- Lights - on, off (when compatible Connect LITE or Connect LITE+ is installed and Light function is Enabled)
- Timers - add, change (if Timers Enabled is selected)
- Chlorine Set Point
- Maintenance Functions

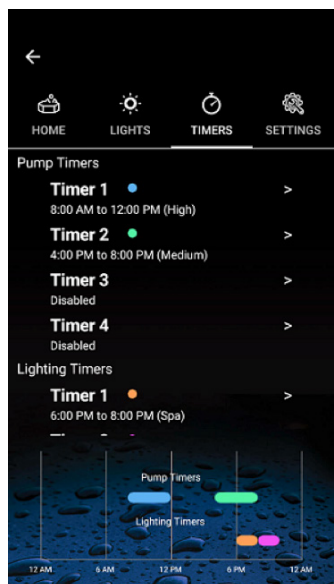

Figure 17. ChlorinatorGo App - Timers

Section 7. Pool Chemistry and Balance

7.1 pH Regulation Principle

The amount of chlorine needing to be produced is dictated by the pH level in the pool. As the pH level rises, the amount of chlorine must be increased to compensate, see below.

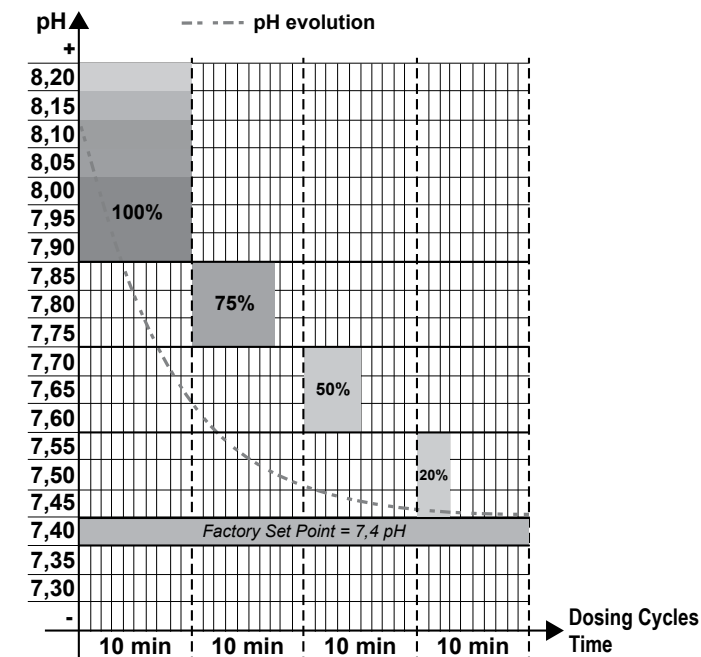

Figure 18. pH Evolution Graph

7.2 Chlorine Output and Filtration Time

Your Chlorinator must be run every day to ensure that your pool is correctly sanitised. As the sun dissipates chlorine, running times are higher in the summer compared to the winter. AstralPool recommend that you initially run your chlorinator at maximum output on level 8.

7.2.1 Summer

Set the Chlorinator to operate for 8 to 10 hours per day. Ideally, run it for 4-5 hours in the morning (between 8-12pm) and 4-5 hours in the evening (between 6.00-11pm).

In extremely hot weather it may be necessary to extend the running time if you find that the free chlorine level is too low.

7.2.2 Winter

You should set your Chlorinator to operate for 6 to 8 hours per day. Again, running it in the morning and evening is preferable. A lower chlorine output level may be selected.

7.3 Water Chemistry

Test and maintain correct water balance throughout the season, according to the table.

	Free Chlorine	pH	Total Alkalinity (ppm)	Calcium Hardness (ppm)	Cyanuric Acid (ppm)	Salt Level (ppm)	Metal
Australian Standard	1 - 3	7.2 - 7.8	60 - 200	100 - 400 ***	up to 50	4000 - 7000	-
Ideal range	1 - 3	7.4	80 - 140	90 - 300	less than 30	4000 at 27°C	< 0.10 ppm
To Increase	Add chlorine or increase equipment output	Add buffer or soda ash (sodium carbonate)	Add sodium bicarbonate	Add calcium chloride	Add cyanuric acid	Add salt or minerals **	-
To Decrease		Add muriatic acid	Add muriatic acid or dry acid	Partially drain and refill pool*	Partially drain and refill pool*	Partially drain and refill pool*	use appropriate metal remover
In Season Testing Frequency	Weekly	Weekly	Weekly	Weekly	Weekly	Monthly	Monthly

NOTE: Test all equipment sensors quarterly.

* Fill pool with water from the mains water supply. Do not use rain water or well water.

** Do not add salt directly into the skimmer. Do not initiate electrolysis until salt has fully dissolved.

*** Reading is True Calcium Hardness, not Total Hardness.

Table 3. Water Chemistry

7.3.1 Chlorine Level.

Ideally, check the Chlorine level after the morning operating period. The free chlorine residual level should be somewhere between 1 and 3 parts per million. Increase or decrease the output of the Chlorinator to get the right residual chlorine level. It may also be necessary to adjust the operating period if you are running at minimum or maximum output.

7.3.2 Stabilizer (Cyanuric Acid)

Stabiliser (also referred to as Sunscreen or Cyanuric Acid) AstralPool do not recommend the addition of stabiliser in a pool controlled with an e-Q chlorinator with chlorine probe fitted. If Dichlor or Trichlor is used to supplement the chlorine production of the e-Q chlorinator or Cyanuric Acid is added to the pool, the set point of the chlorine (ORP) should be turned down.

Cyanuric Acid (CyA) is often recommended by or added to swimming pools to make the available chlorine last longer. It is often called stabiliser or sunscreen. CyA bonds with chlorine ions which prevents the chlorine from oxidizing bacteria and other contaminants. This effectively reduces the oxidation reduction potential (ORP) of the chlorine in your pool.

CyA is used to extend the life of chlorine when the chlorine is manually added in the form of a tablet, granules or liquid and it is not monitored by a measuring device. This reduces the quantity and cost of chlorine used and maintains a residual chlorine in the pool even though manual dosing may take place every 2 or 3 days.

The AstralPool e-Q Chlorinator continually monitors and produces chlorine to suit the pool's chlorine demand and costs very little to convert your pool minerals into chlorine. AstralPool do not recommend the use of CyA in conjunction with a Salt Chlorinator that is suitably sized and incorporates a chlorine (ORP) sensing device to produce chlorine. This includes adding CyA to the pool or supplementing the chlorinator with Dichlor or Trichlor, both of which have CyA as an active constituent. In particular, CyA should not be used in a covered pool, indoor pool or a spa pool.

At most, CyA should be managed and kept within a range of 10 to 20 ppm when used in conjunction with the e-Q chlorinator installed with the Chlorine Sensor. Ongoing use of Trichlor or Dichlor will continue to raise the level of CyA causing a reduction in the activity of the chlorine and may cause your e-Q Chlorinator to continue to raise the chlorine levels to excessive levels in order to reach the chlorine set point (ORP).

If CyA is present in the pool water or Trichlor or Dichlor is used to supplement the Chlorinator's chlorine production then the ORP set point should be adjusted downwards until a chlorine level of between 2 and 5 ppm is achieved and maintained. Consult your pool professional or certified Viron Installer to adjust your Chlorine (ORP) set point.

As a guide, the following set point ORP levels can be used as a starting point to achieve a consistent and reasonable chlorine level.

Chlorine efficiency or activity is reduced even when low levels of CyA is present.

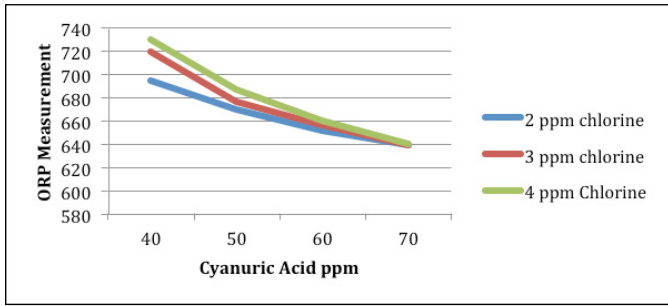

Figure 19. Effects of CyA on ORP Measurements

Total Alkalinity (TA) buffers pH or keeps the pH relatively stable. The pH of your pool water is crucial to making your chlorine highly effective, even when the chlorine is present in low levels. Measuring and adjusting your TA on a regular basis will help reduce acid consumption and help keep your pH level in check. Variable pH will also create variable ORP readings with high pH meaning your e-Q Chlorinator will produce more chlorine to reach the set point ORP level than it would otherwise need.

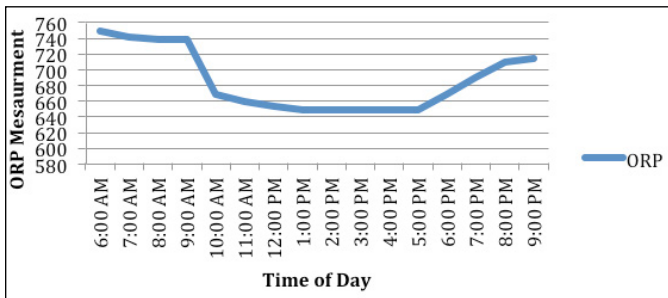

Figure 20. Effects of Sunlight Assisting CyA Bond

CyA (STABLISER) adds to the TA reading. If CyA levels of in excess of 50 ppm are present, it is good practice to divide the CyA by 3 and subtract the result from the TA reading. Therefore if CyA is 60, and TA is 200, subtract 20 (CyA 60/3) from 200 for a TA reading of 180.

CyA bonds to chlorine more effectively in sunlight hours. Therefore ORP readings will be lower in sunlight hours than at night. As the chlorine bonds with CyA during sunlight hours, the ORP may drop more than 100 mv. This means the e-Q chlorinator will drive higher levels of chlorine during sunlight hours as the chlorine is temporarily bonded with CyA. After sunset, the CyA bond with chlorine will reduce, freeing up the chlorine to oxidize with bacteria and exhibiting an increased oxidization potential reading on the e-Q chlorinator.

Cyanuric Acid Level	Chlorine Level		
	2ppm	3ppm	4ppm
0	700 mv	725 mv	750 mv
10	550 mv	600 mv	625 mv
20	500 mv	525 mv	550 mv
>50	350 mv	400 mv	450 mv

NOTE: Contants - pH at 7.6 and TA at 180 ppm

Table 4. Guide to Adjusting ORP Set Point

7.3.3 pH Level

Keep the pH level between 7.0 and 7.4 for fibreglass pools and 7.2 to 7.8 for other pools.

7.3.4 Total Alkalinity

The ideal range is between 80 and 120 ppm.

7.3.5 Salt Level

The correct salt level is important to cell life and the effective operation of your chlorinator. Salt level should be maintained around 4,000ppm but should never be allowed to fall below 3,000ppm. Although salt is not consumed by the Chlorinator, salt is lost during backwashing and when your pool overflows due to rain or splashing.

A typical pool of around 50,000 litres requires 200kg of salt to initially set-up the pool to 4,000ppm.

A low salt level warning is indicated on your e-Q Chlorinator if the salt level drops. If Low Salt is indicated, check again in 24 hours and then if it is still indicated, add two 25kg bags of salt to the shallow end of your pool. Run the filtration system for approx. 6 hours to help mix the salt in the pool. It can take up to a day for the salt to fully dissolve.

If the low salt light is still on, then you should get your pool water tested. If the Salinity is above 4000ppm then you may need to have your Chlorinator checked.

⚠ WARNING

- Do not put salt directly in the skimmer box. High concentrations of salt will be passed through filtration and other pool equipment

7.4 Chlorine Dosing and ORP

The Viron e-Quilibrium uses an ORP sensor to measure and control the chlorine levels in your swimming pool or spa.

Before installing probes, balance pool water. Total Alkalinity (TA) must be 80 to 120 ppm, Calcium Hardness should be 180 to 250 ppm, and pH must be between 7.2 and 7.6.

Dose pool with a small amount of chlorine before starting the e-Q. If no chlorine is sensed the e-Q may go to fail safe mode and not start up. Some Chlorine should be present before starting the unit.

The Chlorine sensor will take 45 minutes or more to accurately sense the chlorine level in the pool. Allow Pool pump to run for 45 minutes before attempting to calibrate the sensor to the pool water.

Confusion often exists about the difference and relationship between oxidization reduction potential (ORP) and chlorine levels measured in parts per million (ppm).

Most pool shops and pool service technicians will focus on chlorine readings in ppm and not the ORP.

ORP is actually a more accurate and important reading than ppm because it measures the effectiveness of chlorine and NOT the level of chlorine in the water. Relying on ppm can provide a false sense of security and may even lead to use of a pool that is dangerous to swim in.

When chlorine is added to the water it reacts to form two separate chemicals, one is hypochlorous acid (HOCl) and the other is hypochloric acid (HCl). The important chemical to form is HOCl as it is the active or effective form of chlorine which oxidizes and disinfects the contaminants in the water.

The amount of HOCl and HCl formed depends on the pH of the water. The higher the pH, the less effective HOCl is formed and the more ineffective HCl is formed. Ideally, a pH range of 7.2 to 7.6 forms the most HOCl while maintaining soothing water to swim in.

At a pH of say 7.8, only 30% effective HOCl will be formed which means the chlorine is not being effective as disinfecting the pool or spa water even though the ppm is 2 or 3 ppm.

However, at a pH of 7.2, a massive 80% effective HOCl will be formed meaning the chlorine is highly effective as disinfecting the water even at levels of 1ppm.

ORP remains the best method to measure the sanitiser's (chlorine's) effectiveness in the water. At a reading of 750mv a virus kill time is as low as one second!

Various other chemicals added to the water can affect the ORP. For example, most pools will have cyanuric acid added to the water which effectively slows down the reaction of the chlorine to make it last longer. However, the slower reaction time of the chlorine lowers the ORP, hence the e-Quilibrium will add more chlorine to maintain the ORP and keep your pool healthy and safe to swim in.

Section 8. Maintenance

Your Viron e-Quilibrium Chlorinator requires regular maintenance to sense the chlorine and pH levels accurately and to safely dose the pH adjuster (hydrochloric acid).

8.1 Regular Scheduled Maintenance

Frequency	Maintenance
Weekly	Check Acid level and replace or top up as required
Monthly*	Manual test for pH and chlorine and adjust eQ set point as required Test and adjust Total Alkalinity, CyA levels, and Calcium Hardness levels and adjust to levels recommended by your professional pool shop or service technician
Every 3 months	Spray a surface insecticide on the surfaces around the unit to prevent ant and insect ingress. To protect against extremes of temperature, your unit is vented to allow expensive electronics to cool. Ants and some insects are often attracted to the warmer, dry environment inside the enclosure. We recommend that, with power turned off, you spray a surface insecticide on the surfaces surrounding the control to prevent ant and insect ingress. Repeat every three months or as necessary
Every 6 months***	Using a cotton bud and Jif (non abrasive cleaner) clean pH. Rinse in clean water or clean pool water. Re install, allow 24 hours to settle and sense correct levels. Adjust set points or calibrate sensors as required Inspect Acid tube, peristaltic pump squeeze tube condition for cracks, wear and tear. Replace as required

* Water tests should be conducted by a professional pool shop or service technician. Use a clean sample bottle and take sample from approximately 30 cm below water level. Take sample to pool shop immediately. Sample bottles can usually be obtained from your local professional pool shop.

*** It is recommended that a pool professional test, clean and calibrate the pH and chlorine sensors.

8.2 Lubricate the Acid Pump Squeeze Tube

Acid pump squeeze tube must be lubricated every 6 months or more often in commercial applications. Use only the recommended lubricant RC Tube Lube available from AstralPool or any other compatible silicone lubricant, otherwise damage to the tube is possible.

Depending upon usage, the squeeze tube may need replacement after 12 months on a domestic installation, and earlier on a commercial installation. Before replacing the tube make sure that any stop valves in the filter system are closed. Otherwise water loss may occur.

To replace the tube, remove controller drawer, remove retaining screws from the pump head and pull the tube free. Disconnect the squeeze tube from the barbs and reconnect the new squeeze tube after lubricating the same, making sure that the new tube is correctly connected to the PVC tubing as per instructions. Reposition the squeeze tube in the unit as before, replace the pump head and retaining screws.) **DO NOT OVERTIGHTEN THE RETAINING SCREWS.**

8.3 Clean and Calibrate Sensors

The sensors are sensitive instruments. To maintain their accuracy they should be cleaned and calibrated regularly.

8.3.1 Sensor Cleaning

To maintain accuracy, clean sensors periodically with a household detergent abrasive (Jif is the preferred option).

The Chlorine Sensor tip can be contaminated (generally observed by a copper or brownish coating – this should always look shiny gold) which will give a false reading to the Controller causing no dosing/over dosing of chlorine. As the pH sensor tip is made of glass, please take care, for even a hairline crack can cause the sensor to read incorrectly causing malfunction.

After cleaning the sensors, wash with water, allow 5-10min. to settle and check calibration or re-calibrate if necessary.

NOTE: The chlorine sensor may take 30 to 45 minutes to settle and provide the correct reading.

8.3.2 Sensor Calibration

Calibrate the pH sensor every 6 to 12 months.

1. To Calibrate, Press MAINT and next until CAL appears on the LCD.
2. Select CAL to commence the process.

The pH probes/sensor has been factory calibrated. However it is a good practice to check the adjustment for the probe periodically (every 6 months or earlier if required). The probe should be cleaned first (refer under Maintenance page for cleaning) and allowed to settle down for about 4-5 minutes before adjusting/calibrating. The most accurate way to calibrate is to put the probe in a calibration solution. Calibration solution is available via AstralPool as a spare part.

Press MAINT and then next until CAL is displayed. The unit will ask CHANGE PH CALIBRATION, select YES. Select NO to Filter Pump on?

Section 9. Ai Mode

Ai Mode is complete automatic control of your Pool & Spa. Ai Mode is a unique Patent Applied for system that controls the filtration and chlorine levels in your pool with three primary objectives:

- Completely turnover your pool water every day so that the organic material which looks unsightly and which feeds algae and bacteria is removed from your pool.
- Ensure the correct sanitizer level is achieved to destroy any pathogens, algae and bacteria in the water.
- Minimize the cost of operating your pool and spa.

Ai Mode will automatically adjust operating times, pump speed (when Viron variable speed pumps are installed) and chlorinator output to suit the weather conditions and bather load.

Priority one is to produce sufficient chlorine to make the pool clean, healthy and ideal to swim in.

Priority two once the pool is clean is to reduce operating costs by automatically reducing the pump speed.

9.1 Ai Equipment Requirements

For your Viron e-Quilibrium to operate in Ai Mode you will need the following equipment:

- A Viron e-Quilibrium
- pH sensor
- chlorine sensor
- RJ12 communications cable
- Viron eVo variable speed pump

9.2 Ai Mode Connection

Connect your Viron eVo pump to the Viron e-Equilibrium with the RJ12 communications cable and plug the 3 pin plug into the bottom.

9.3 Ai Mode Set Up

In the Viron e-Equilibrium "Set Up" screen:

1. Enter "INSTALL" menu and enable the following:
 - 3 speed pump enabled the volume of your pool and spa in litres (if no spa is installed, leave this at factory pre-set level)
 - Select Ai Mode
 - Select the size Viron Pump you have installed (1.0 hp for P320/XT320 and 2.0 hp for P600/XT520)
 - Select the speed of the pump when you have the system manually on – we recommend speed 1 or high speed.
 - Select "Continue" set up when asked.
 - the number of complete water turnovers required each day, (suggest factory preset of 1.5 times is adequate)
 - When asked "Reset to Factory Defaults?" select no.
2. Exit the "Install Menu"
3. Change the timer period to operate for as long as possible (suggestion of 16 hours – from 8 am to 10 pm)

9.3.1 Viron eVo Pump speed selection:

1. Enable System mode in the Viron Pump menu – refer to your Viron Pump Instructions
2. Set Pump speeds as follows:
 - With the RJ12 Cable connected to the pump and eQ Chlorinator, change chlorinator mode to "Manual On" to enable adjustment of the Pump Speeds.
Note: Othe pump is turned Manual On, it will go into Priming Mode for 5 minutes before the speeds can be changed.
 - Set High Speed at near maximum speed of the pump.
 - Set Medium Speed at a speed so the chlorinator electrode cell fills with water during operation and the skimmer box weir door creates some surface tension on nearby water to skim properly. Usually, this speed will be between 1200 and 1600 RPM.
 - Set Low Speed at 600 RPM (also referred to as sampling speed). Ensure water is flowing through the chlorinator cell at this speed.

9.4 Operation in Ai Mode.

In Ai Mode, the pump and electrode cell will start at the first time setting. After an initial 5 minute priming period, the pump will revert to filter speed (Medium Speed), the Chlorinator will test pH and chlorine levels and both adjust the chlorine production and dose acid to achieve the desired levels.

The Viron e-Equilibrium will ensure the pump operates until its primary two objectives are achieved:

- Water is turned over 1.5 times (on a 50,000 litre pool, the pump will move 75,000 litres of water to ensure all of the water is filtered)
- Chlorine level is achieved. In the winter, this may be only 4 to 6 hours of operation. In the summer, when the pool is subject to high UV and heavy bather load it may be 12 hours as the chlorine level is constantly under demand.

When both objectives are achieved, the Viron e-Equilibrium will turn the pump down to Sampling Speed (approx.600 RPM) which is almost inaudible and costs less than 0.5 cents per hour. During sampling speed the Viron e-Equilibrium simply tests for chlorine levels. If the family all jump in the pool later at night and the chlorine is dissipated, the Viron e-Equilibrium will turn the pump back to filter speed (medium) and turn the electrode on to produce more chlorine. Your family is protected even when swimming later at night as the system is filtering and sanitising the pool or spa water automatically.

If the correct chlorine level is NOT achieved when the system shuts down at the end of the day on time clock, it will start on maximum output and maximum pump speed the following morning until the chlorine level is achieved. Once the chlorine level is achieved, the pump will revert back to the gentle filtration speed until the required number of water turns and chlorine levels are maintained.

9.5 Ai Mode Timers

In Ai Mode you can select four timer periods. Each timer period can have a specific pump speed selected (high or medium) or allow the Chlorinator to select the appropriate pump speed. Normally you will only select a specific pump speed when you wish to operate a cleaner or water feature at a specific time every day. Low speed cannot be selected in Ai Mode as low speed becomes the default "sampling speed" to allow the unit to continue to monitor chemical levels while the Viron Pump is operating at a very low output.

9.6 Effects of Ai Mode

It is important, during set up, that the pool/spa volume is entered correctly. The average pool size in Australia is between 50,000 and 60,000 litres but if in doubt, it is better to select more volume than less.

When chlorine is low, Ai mode will change the Viron Pump (if installed and connected) to High Speed. The high speed can be adjusted up or down in the set up and commissioning stage.

High speed operation and high chlorine output will continue until the chlorine reading is near the set point. Once the chlorine level nears set point, Ai mode will turn the pump speed back to medium and reduce the output on the chlorinator to prevent "overshooting" of chlorine levels.

When the chlorine level is satisfied and the pump has operated long enough to complete the pool water turnover inputted into the Chlorinator set up menu (factory pre-set at 1.5 turns), the chlorinator will turn the pump down to low speed, stop producing chlorine and dosing acid, but continue to sample the chlorine level. Low speed should be adjusted to approximately 600 to 800 RPM during set up.

If the chlorine level drops significantly while in Ai mode, the eQ will turn the pump back to medium speed (from low speed) or to high speed (from medium speed). At the same time, the chlorine output will automatically be adjusted. The goal is to produce chlorine as quickly as possible and vigorously circulate chlorinated water to all parts of the swimming pool.

You will notice a difference in the operating hours, pump speed and chlorinator output between winter and summer as the unit adjusts to weather and environmental conditions.

9.6.1 Extended Hours and High Speed Pump Operation

Should Ai mode keep your pump in high speed for most of the day perform the following checks:

1. Manually test the water (from in front of skimmer or inlet to the circulating pump) for the chlorine level. If the chlorine level is high (above 3ppm) turn the chlorine setting on the chlorinator down. (Refer to section 10.1)
2. If the chlorine level is low and stays low throughout the day, try extending the operating hours of the Chlorinator into the morning or late at night. Chlorine produced at night will stay in the water for longer and build up a residual which may be enough to counter the effects of strong sunlight and bather load on hot days.
3. Check the salt or mineral level in your pool water. Higher levels (do not exceed 6000 ppm) of salt/minerals will enable higher chlorine production.

After these checks, if the pump stills runs on high speed for most of the day, you can sacrifice circulation by reducing the high speed setting on the pump

Visit our online support page which has a range of videos on Setup, Maintenance, and Troubleshooting.
Go to: www.astralpool.com.au/eq-support

Section 10. Troubleshooting

When there is an error condition, a message is displayed on the screen and the "INFO" LED flashes. When an error is linked to conductivity (low conductivity) the "SALTS" LED is ON. When the error situation is corrected, the error message and LED illumination ends automatically.

Fault Indication	Possible Cause	Remedy
No Flow	<ul style="list-style-type: none"> Pump turned off/disconnected or valves closed Sense wire disconnected from cell 	<ul style="list-style-type: none"> Ensure valves/pump on Connect sense wire to cell
Low salt	<ul style="list-style-type: none"> Salt level in pool has dropped too low Pool water temperature is low Cell has failed 	<ul style="list-style-type: none"> Increase salt level or raise water temperature Call a technician
Sense wire disconnected from cell	<ul style="list-style-type: none"> For models with a temp sensor this error can be caused by low conductivity. Lack of salt < 4000 ppm due to water loss or dilution (filter backwash, water renewal, rain, leaks, etc.). Can vary depending on the temperature and age of the cell. The voltage across the cell terminals varies in time. Cell calcified, worn, or out of order. 	<ul style="list-style-type: none"> Check water temperature. Check the condition of the cell plates. Measure the salt concentration in the pool water using a salt tester or a test strip, then add salt to the pool to keep the level at 4000 ppm. If you do not know the salt level or how to test it, contact your retailer. Is the salt level is correct?
Check Light Mode	<ul style="list-style-type: none"> A Light Timer is set, but the light is set to ON or OFF instead of AUTO 	<ul style="list-style-type: none"> Use the "LIGHT" button or RF remote control to set the Light to AUTO mode
Check Timer	<ul style="list-style-type: none"> The Pump is set to OFF in all timers 	<ul style="list-style-type: none"> Modify timers so that the Pump is on in at least 1 timer.
Display blank	<ul style="list-style-type: none"> No Power to Controller Fuse blown 	<ul style="list-style-type: none"> Plug in controller and ensure mains power available Call a technician
Low/No chlorine production	<ul style="list-style-type: none"> Cables not connected to cell Timer period too short Chlorine output level too low Filter needs backwashing Pool stabiliser too low Salt level too low Water Temperature below 15 deg Excessive Salt Level (Above 10,000 ppm) The e-Q has locked out on fail safe with very low chlorine levels present (less than 100 mv ORP) 	<ul style="list-style-type: none"> Connect cables Increase timer period Increase chlorine output Backwash filter Get Stabiliser between 30 and 60 ppm Increase salt to 4000ppm Increase water temperature or salt level Chlorinator cuts out on overload, reduce salt level to 4000 ppm Test Chlorine levels and add chlorine to pool. Start pool pump and allow one hour for sensor to read chlorine levels
Pool water cloudy	<ul style="list-style-type: none"> Chemical balance in incorrect Acid container empty ORP level set too low Pool water volume set too low in install menu Insufficient Water flow Insufficient water turnovers each day 	<ul style="list-style-type: none"> Test Water and adjust as needed pH 7.2 to 7.6, TA to 120 ppm and CH to 180ppm Replace Acid Container Set ORP to 700 mv Increase pool water volume Increase variable speed of pump Increase water turns in Install menu
pH too high	<ul style="list-style-type: none"> Probe/sensor malfunction 	<ul style="list-style-type: none"> Clean and calibrate probe/sensor
Chlorine too high	<ul style="list-style-type: none"> ORP level is set too high Total Alkalinity too low ORP sensor is not immersed in pool water Cyanuric Acid (Chlorine Stabiliser) is present in pool 	<ul style="list-style-type: none"> Reduce to between 600 and 650 mv ORP Test TA and adjust to 80 to 120 ppm Install sensor chamber so that it is always in pool water Lower ORP set point

Table 5. Troubleshooting

Section 11. Exploded Diagram and Parts List

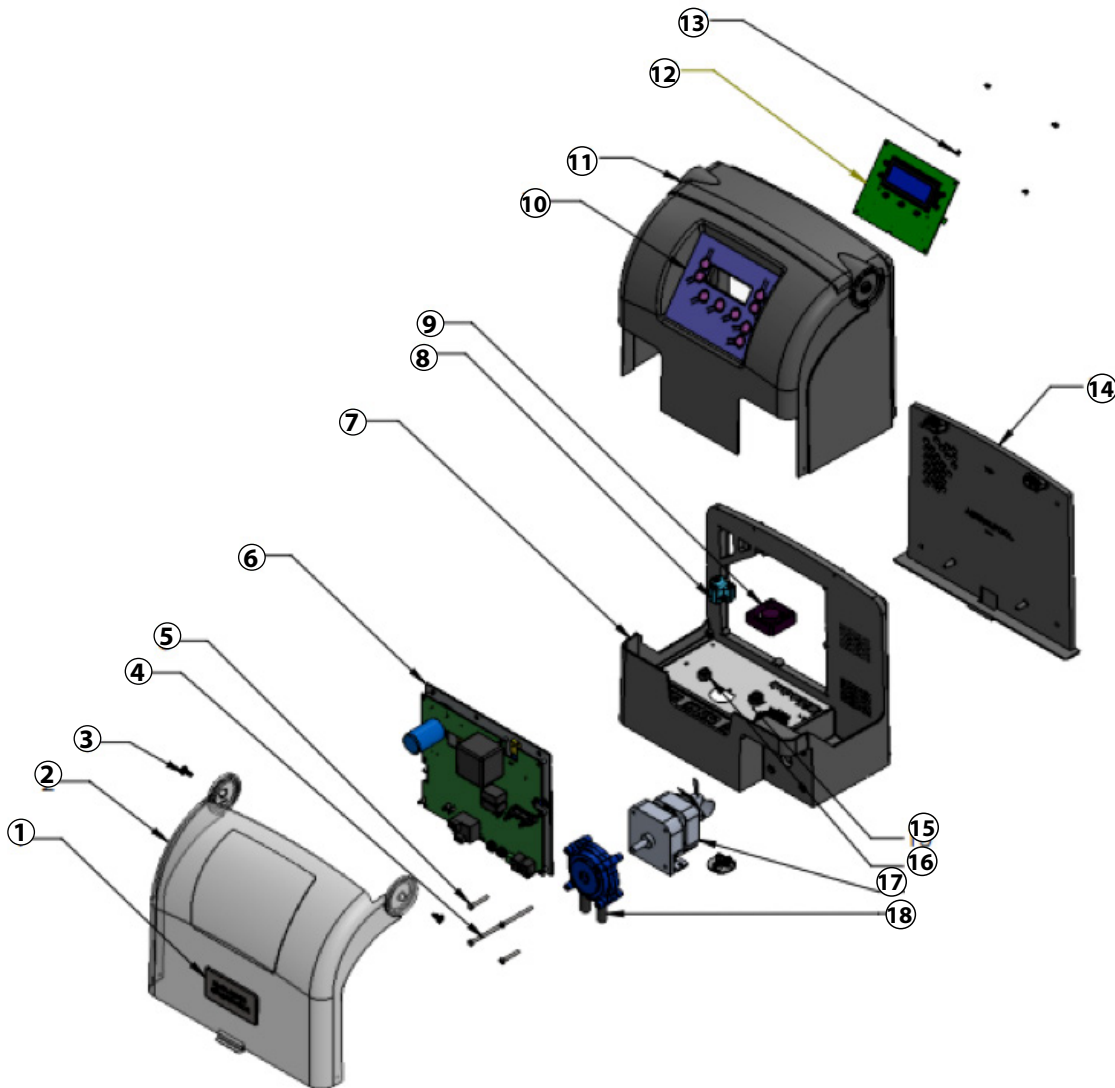

Item	Description	Part Number	Quantity
1	Label	LABEL371	1
2	Trans Grey Plastic Visor	950903	1
3	Visor Hinge Pins	520160	2
4	Screws Long - for Pump	221117	2
5	Screws Short - for Pump	221118	2
6	Main PCB	SP71404	1
7	Main Body	950908	1
8	3 Pin Plug Base	20026	1
9	Cooling Fan	2030037	1
10	Label - Facia	LABEL256	1
11	Main Cover	950902	1
12	PCB - User	71401	1
13	Screws for User PCB	395201	4
14	Wall Mount Bracket	950905	1
15	Cell Cable Strain Relief	20028	1
16	Power Cable Strain Relief	20008	1
17	Pump Motor - 5 RPM	524750	1
18	Pump Faces - Blue	521010	2

not shown	SQUEEZE TUBE	520112
not shown	POWER CABLE	350029
not shown	CELL CABLE	71400
not shown	COMPONENT BAG	78300
not shown	Instruction Manual	INST464
not shown	CELL - for 12803 (internal only)	11915
not shown	CELL - for 12804 (internal only)	11916
not shown	CELL - for 12805 (internal only)	11917
not shown	CELL - for 12806 (internal only)	11918

Section 13. Warranty

13.1 Warranty Terms

This product is sold with a limited factory warranty. For warranty terms and conditions, please visit:

www.astralpool.com.au

All warranty issues should be resolved with your AstralPool dealer or place of purchase. Claims must include the serial number and model (this information can be found on the product), installation date, and name of the installer. Shipping costs are not included in the warranty coverage.

The warranty does NOT cover damage caused by improper assembly, installation, operation or field modification. Also, any damage caused by improper water chemistry will NOT be covered by the warranty.

NOTE: Keep this manual in a safe place for future reference when inspecting or servicing the product.

13.2 Consumer Information and Safety

The product is designed and manufactured to provide many years of safe and reliable service when installed, operated, and maintained according to the information in this manual and the installation codes referred to throughout. Be sure to read and comply with all warnings and cautions.



For full warranty terms and conditions and to register your warranty, visit **www.astralpool.com.au/warranty** and complete your details. Or scan the QR code to go directly to the registration page

Record your equipment details here for quick reference:

Model No. : _____

Serial No. : _____



INST464

Fluidra Group Australia Pty Ltd
219 Woodpark Road
Smithfield NSW2 2164, Australia



1 300 186 875
www.astralpool.com.au