

Operating Instructions Microwave oven



To avoid the risk of accidents or damage to the appliance, it is **essential** to read these instructions before it is installed and used for the first time.

Contents

Warning and Safety instructions	4
Before using for the first time	14
Installation	15
Building-in dimensions.....	15
Electrical connection.....	20
Caring for the environment	21
Guide to the appliance	22
Control panel	23
Description of the functions	24
Modes of operation	25
Functions.....	25
Microwave Solo mode.....	25
Automatic programmes.....	25
Suitable containers for microwave use	26
Material and shape.....	26
Testing containers	29
A microwave lid or cover.....	29
Before using for the first time	31
Setting the time of day	31
Altering the time of day	31
Operation	32
Opening the door	32
Placing a dish in the oven	32
Turntable.....	32
Closing the door.....	32
Starting a programme	32
“door” message.....	33
Interrupting or restarting a programme	33
Altering the settings.....	33
Cancelling a programme	34
At the end of a programme	34
Automatic keeping warm function.....	34
Quick microwave.....	34
Changing the duration and power level	34
System lock.....	35

Using the minute minder	36
Altering a minute minder entry	36
Cancelling the minute minder.....	36
Minute minder + cooking process.....	36
Operation - Automatic programmes.....	37
Automatic defrosting	37
Automatic cooking	37
Cooking food from frozen.....	37
Cooking fresh food.....	37
Using an Automatic programme	37
Recipes - Automatic programmes.....	39
Changing settings	41
Reheating	44
Cooking	46
Defrosting.....	47
Bottling	48
Examples of use	49
Cleaning and care	51
Problem solving guide	54
After sales service.....	57
Contact in case of fault	57
Warranty	57

Warning and Safety instructions

This appliance complies with current safety regulations. However, inappropriate use can lead to personal injury and damage to property.

Read the Operating instructions carefully before using the appliance. They contain important information on safety, installation, use and maintenance of the appliance. This prevents both personal injury and damage to the appliance.

In accordance with standard IEC 60335-1, Miele expressly and strongly advises that you read and follow the instructions in “Installation”, as well as in the “Warning and Safety instructions”.

Miele cannot be held liable for injury or damage caused by non-compliance with these instructions.

Keep these instructions in a safe place and pass them on to any future owner.

Correct application

▶ The microwave oven is intended for use in private households.

This appliance is not intended for outdoor use.

▶ Do not use the appliance at altitudes above 2000 m.

▶ The microwave oven is intended for domestic use only to cook, defrost and reheat food. Any other use is not permitted.

▶ If flammable items were dried in the microwave oven, the moisture in the items would evaporate. This could cause them to dry out and possibly self-ignite. Never use the microwave oven to store or dry items which could ignite easily.

Warning and Safety instructions

- ▶ This microwave oven is not intended for use by people (including children) with reduced physical, sensory or mental capabilities or lack of experience and knowledge, unless they have been given supervision and instruction concerning its use by a person responsible for their safety. They may only use the appliance unsupervised if they have been shown how to use it in a safe way. They must be able to recognise the dangers of misuse.
- ▶ This appliance is equipped with a special lamp to cope with particular conditions (e.g. temperature, moisture, chemical resistance, abrasion resistance and vibration). This special lamp must only be used for the purpose for which it is intended. It is not suitable for room lighting. Replacement lamps may only be fitted by a Miele authorised technician or by Miele.

Safety with children

- ▶ Young children must not be allowed to use the appliance.
- ▶ Older children may use the appliance without supervision if its operation has been clearly explained to them and they are able to use it safely. Children must be able to recognise and understand the potential risks of improper use.
- ▶ Children must not be allowed to clean or maintain the appliance unsupervised.
- ▶ Please supervise children in the vicinity of the microwave oven and do not let them play with it.
- ▶ Danger of suffocation! Whilst playing, children may become entangled in packaging material (such as plastic wrapping) or pull it over their head with the risk of suffocation. Keep packaging material away from children.

Warning and Safety instructions

Technical safety

- ▶ A damaged appliance could be dangerous. Check the appliance for visible signs of damage. Do not use the appliance if it is damaged.
- ▶ If the electrical connection cable is damaged it must only be replaced by a Miele authorised service technician in order to prevent a hazard.
- ▶ Operating a damaged appliance can result in microwave leakage and present a hazard to the user. Do not use the appliance if
 - the appliance door is warped.
 - the door hinges are loose.
 - holes or cracks are visible in the casing, the door or the oven interior walls.
- ▶ Any contact with live connections or tampering with the electrical or mechanical components of the microwave oven will endanger your safety and may lead to appliance malfunctions. Do not open the appliance housing under any circumstances.
- ▶ Before connecting the appliance to the power supply, ensure that the connection data on the data plate (voltage and frequency) match the mains electricity supply. This data must correspond in order to avoid the risk of damage to the appliance. If in doubt, consult a qualified electrician.
- ▶ Do not use multi-socket adapters and extension leads to connect the microwave oven to the electricity supply. They are a fire hazard and do not guarantee the required safety of the appliance.
- ▶ The electrical safety of this microwave oven can only be guaranteed when continuity is complete between it and an effective earthing system. It is essential that this standard safety requirement is met to avoid the risk of damage or electric shock due to a missing or disconnected protective conductor. If in any doubt, please have the electrical installation tested by a qualified electrician.

Warning and Safety instructions

- ▶ For safety reasons, this appliance may only be used when it has been built in.
- ▶ Unauthorised installation, maintenance and repairs (including removal of any cover) can cause considerable danger for the user. Installation, maintenance and repairs must only be carried out by a Miele authorised technician.
- ▶ Any repairs not performed by a Miele authorised technician will void the warranty.
- ▶ During repairs or cleaning and maintenance, the microwave oven must be disconnected from the mains power supply. It is only completely isolated from the electricity supply when:
 - the plug has been disconnected from the back of the appliance or the appliance has been switched off at the wall socket and the plug withdrawn.Do not pull the mains connection cable but the mains plug to disconnect your appliance from the mains electricity supply.
 - the mains circuit breaker is switched off.
 - the screw-out fuse is removed (in countries where this is applicable).
- ▶ The manufacturer can only guarantee the safety of the appliance when Miele replacement parts are used. Faulty components must only be replaced by genuine Miele spare parts.
- ▶ If the appliance is installed behind a kitchen furniture door, it may only be used with the furniture door open. Do not close the furniture door while the appliance is in use. Heat and moisture can build up behind the closed furniture door. This can result in damage to the appliance and furniture unit. Leave the furniture door open until the appliance has cooled down completely.
- ▶ The appliance must not be used in a non-stationary location (e.g. on a ship).
- ▶ Reliable and safe operation of this microwave oven can only be assured if it has been connected to the mains electricity supply.

Warning and Safety instructions

Correct use

▶ Always ensure that food is sufficiently cooked or reheated.

The time required for this depends on a number of factors, such as the nature of the food, its initial temperature, the amount to be cooked and recipe variations.

Some foods may contain micro-organisms which are only destroyed by thorough cooking at sufficiently high temperatures (over 70 °C) for long enough (a minimum of 10 minutes). Therefore when cooking or reheating foods, e.g. poultry, it is particularly important that food is fully cooked through. If in any doubt that a sufficiently high temperature has been reached, continue reheating for a little longer.

▶ It is important that the temperature in the food being cooked is evenly distributed and sufficiently high.

This can be achieved by stirring or turning the food, and observing a sufficiently long standing time (see charts) which should be added to the time needed for reheating, defrosting or cooking. During the standing time the temperature is distributed evenly in the food.

▶ Always remember that times for cooking, reheating and defrosting in a microwave oven are usually considerably shorter than with traditional methods of cooking food.

Excessively long cooking durations can lead to food drying out and burning, or could even cause it to catch fire. Fire hazard! There is also a danger of fire if breadcrumbs, flowers, herbs etc. are dried in the microwave oven. Do not dry these items in the microwave oven.

▶ Cushions or pads filled with cherry kernels, wheat grain, lavender, or gel, such as those used in aromatherapy can ignite when heated, even after they have been removed from the microwave oven. Do not heat these up in the microwave oven. Fire hazard!

▶ The microwave oven is not suitable for cleaning or disinfecting items. Items can get extremely hot and there is a danger of burning when the item is removed from the appliance. Fire hazard!

Warning and Safety instructions

- ▶ The appliance can be damaged if it is used without food being placed in it or if it is incorrectly loaded. Therefore do not use the appliance to preheat crockery or to dry herbs or similar items.
- ▶ Always ensure that food, a gourmet plate or a browning dish has been placed in the microwave, and that the turntable is in place, before switching on.
- ▶ Pressure can build up when reheating food or drinks in sealed containers, jars or bottles, which can cause them to explode. Never cook or reheat food or liquids in sealed containers, jars or bottles. With baby bottles, the screw top **and** teat must be taken off.
- ▶ Be careful when removing dishes from the appliance. Although heat is not normally produced in the container itself by the microwaves (apart from stoneware), heat transfer from the food to the container may be considerable, making the container itself hot. The dish is only warmed by the heat of the food. Before serving, always check the temperature of the food itself after taking it out of the microwave. The temperature of the container is not an indication of the temperature of the food or liquid in it. **This is particularly important when heating food for babies, children, and the elderly or infirm.** After reheating food, especially food for babies and small children, stir the food or shake the container and check that the temperature does not pose any danger of burning. Double check after it has been left to stand.

Warning and Safety instructions

▶ When heating liquids, milk, sauces etc. using microwave power, the boiling point of the liquid may be reached without the production of the typical bubbles. Liquids do not boil evenly throughout. This so-called 'boiling delay' can cause a sudden build-up of bubbles when the container is removed from the oven or shaken, which can lead to the liquid boiling over suddenly and explosively. Danger of burning and scalding!

The formation of bubbles can be so strong that the pressure forces the oven door open. Danger of injury and damage to the appliance! Stir liquids well before heating. After heating, wait at least 20 seconds before removing the container from the oven. In addition, during heating a glass rod or similar item, if available, can be placed in the container.

▶ To avoid fuelling any flames, do not open the oven door if smoke occurs in the oven interior.

Interrupt the process by switching the appliance off and disconnect it from the electricity supply.

Do not open the door until the smoke has dispersed.

▶ Oils and fats can ignite if allowed to overheat. Never leave the microwave oven unattended when cooking with oil or fats. Do not use the appliance for deep frying. Never attempt to put out oil or fat fires with water. Switch the microwave oven off and extinguish the flames by leaving the door closed.

▶ Due to the high temperatures radiated, objects left near the microwave oven when it is in use could catch fire. Do not use the appliance to heat up the room.

▶ If using alcohol in your recipes, please be aware that high temperatures can cause the alcohol to vaporise. The vapour can catch fire on hot surfaces. Never heat undiluted alcohol in the microwave, as it can easily ignite. Fire hazard!

Warning and Safety instructions

- ▶ Food which is stored in the oven or left in it to be kept warm can dry out and the moisture released can lead to corrosion damage in the microwave oven. This can also cause damage to the control panel, benchtop and surrounding kitchen furniture. Always cover food that is left in the oven to keep warm.
- ▶ Try to avoid the interior walls being splashed with food or liquids containing salt. If it does happen, wipe these away thoroughly to avoid corrosion on the stainless steel surface.
- ▶ The oven interior can get hot during use. Danger of burning! Clean the oven interior and accessories as soon as it has cooled down. Waiting too long can make cleaning unnecessarily difficult and in some cases impossible. Stubborn soiling could damage the microwave oven in certain circumstances and could even be dangerous. Fire hazard!
Please refer to the relevant instructions in “Cleaning and care”.
- ▶ Fire hazard! Plastic containers which are not suitable for use in microwave ovens can be badly damaged and cause damage to the appliance if used. Do not use any containers or cutlery made from or containing metal, aluminium foil, lead crystal glassware, temperature-sensitive plastics, wooden utensils or cutlery, metal clips or plastic or paper covered wire ties. Do not use bowls with milled rims, or plastic pots with the foil lid only partially removed (see “Suitable containers for microwave use”).
Using these items could result in damage to the container and/or present a fire risk.
- ▶ Disposable plastic containers must be specified by the manufacturer as suitable for use in a microwave oven.
Do not leave the oven unattended when heating or cooking food in disposable containers made of plastic, paper or other inflammable materials.

Warning and Safety instructions

- ▶ Heat-retaining packaging consists of, among other things, a thin layer of aluminium foil. Microwaves are reflected by metal. This reflected energy can, in turn, cause the outer paper covering to become so hot that it ignites.
Do not use heat-retaining packaging for warming food in the microwave oven, such as bags for grilled chicken.
- ▶ If you cook eggs without their shells using microwave power, the yolks could explode due to the resulting pressure. Prick the yolk several times before cooking to avoid this.
- ▶ Eggs heated in their shells using microwave power can burst, even after they have been taken out of the oven. Eggs can only be cooked in their shells in a specially designed egg-boiling device. Do not reheat hard-boiled eggs in the microwave oven.
- ▶ Food with a thick skin or peel, such as tomatoes, sausages, potatoes and aubergines can burst when heated. Pierce or score the skin of these types of food several times to allow steam to escape.
- ▶ Dishes with hollow knobs or handles are not suitable for use in a microwave oven. Moisture which has gathered in the hollow recesses can cause pressure to build up and the items can explode (this risk is reduced if the hollow recess is sufficiently ventilated). We recommend that you do not use such dishes in the microwave oven.
- ▶ Do not use a thermometer containing mercury or liquid as these are not suitable for use with very high temperatures and break very easily.
To check food temperature, first interrupt the cooking process. Only use a thermometer specifically approved for food use to measure the temperature of the food.
- ▶ The steam from a steam cleaner could reach electrical components and cause a short circuit. Do not use a steam cleaner to clean the appliance.

Accessories

▶ Only use original Miele accessories. If other parts are used, warranty, performance and product liability claims will be invalidated.

Before using for the first time

After unpacking, let the appliance stand for approx. 2 hours at room temperature after transporting it to its final location before connecting it to the electricity supply.

This is to allow time for the temperature to equalise between the temperature in the room and the appliance. This is important for the correct electronic functioning of the appliance.

⚠ Risk of suffocation from packaging material.

Whilst playing, children may become entangled in packaging material (such as plastic wrapping) or pull it over their head with the risk of suffocation.

Keep packaging material away from children.

- Remove all packaging materials from the appliance.

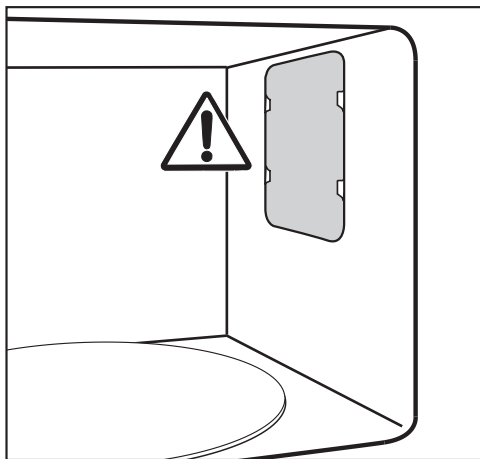

Do not remove the cover of the microwave outlet inside the oven, nor the film covering the inside of the door.

- Check the appliance for any damage.

⚠ Danger to health due to a defective appliance.

Operating a damaged appliance can result in microwave leakage and present a hazard to the user.

Do not use the appliance if

- the appliance door is warped.
- the door hinges are loose.
- holes or cracks are visible in the casing, the door or the oven interior walls.

- Clean the inside of the oven and all the accessories with a soft sponge and warm water.

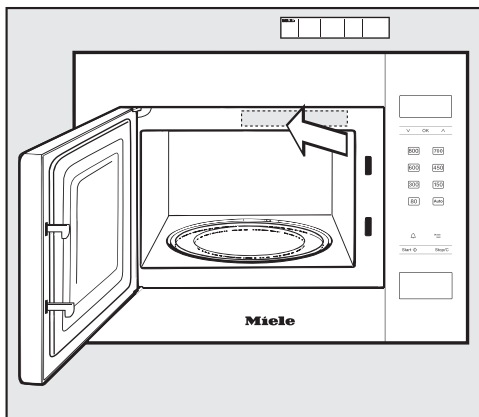

- Stick the enclosed quick start guide to the frame behind the door as illustrated, making sure it does not block any of the vents.

When building in the appliance, ensure that air entering and leaving the front of the appliance is not hindered.

Therefore, do not block the ventilation gaps with any objects. There should be a gap of 2.5 mm on each side of the furniture unit front, and 4 mm at the top.

To transport the appliance, make sure that you lift it by the housing and not by the fascia. The fascia is not sturdy enough to bear the weight of the appliance when it is being carried.

The appliance is designed to be built into a tall unit and is also suitable for underbench installation.

The installation of the microwave oven below a cooktop or above a warming drawer is not permitted.

Building-in dimensions

Dimensions are given in mm.

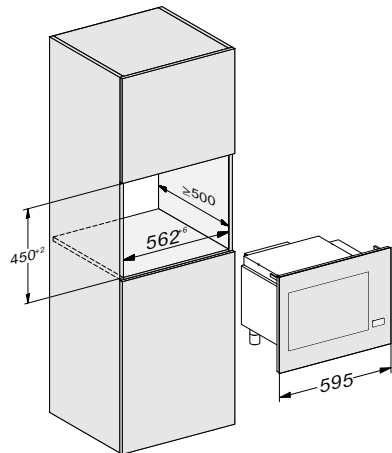
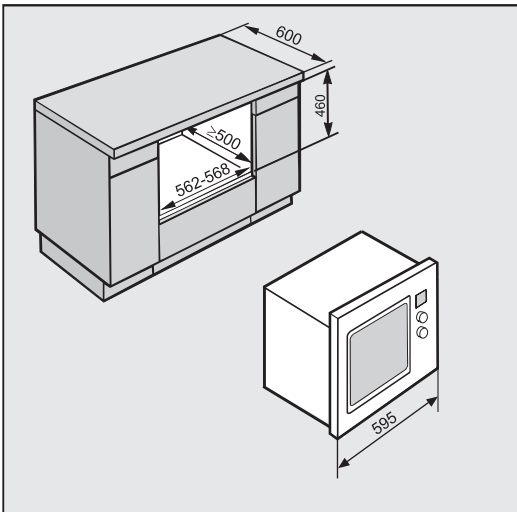

Installation

Side view

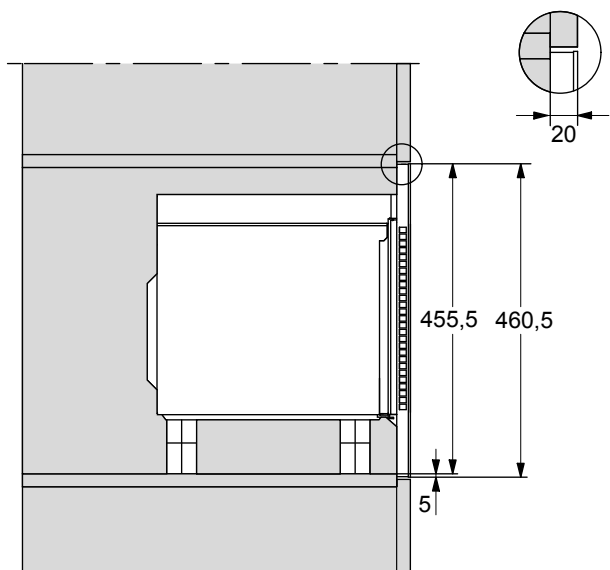

Connection

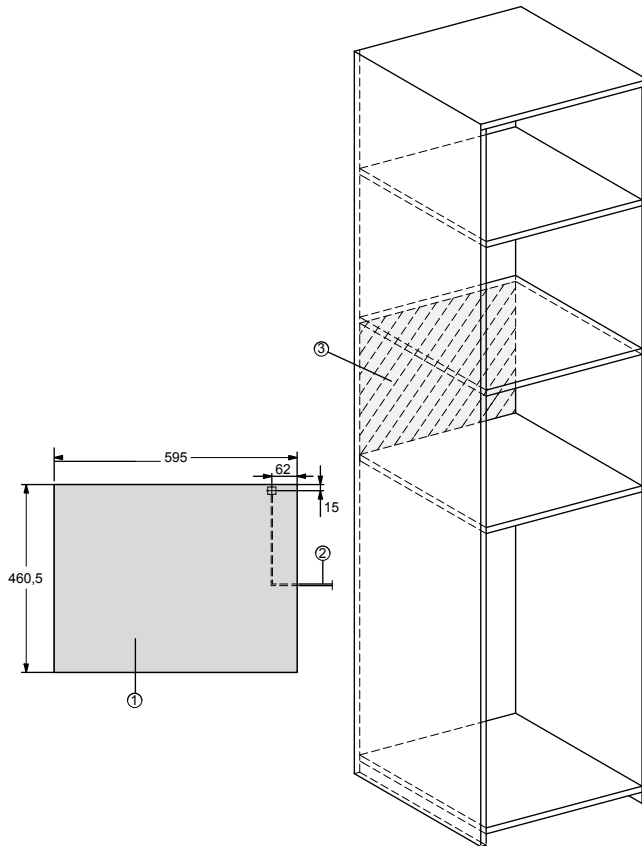

- ① Front view
- ② Mains connection cable,
length = 1,600 mm
- ③ No connections permitted in this area

Installation

Building-in kit

The following items are supplied in the accessory pack for installing the appliance:

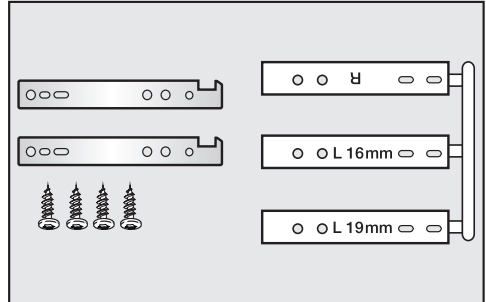

Carrying out installation

The appliance must be built in before it can be used.

There are three spacers in the accessory pack: one for the right-hand side (R) and two for the left-hand side (L), depending on whether the housing unit wall is 16 or 19 mm thick.

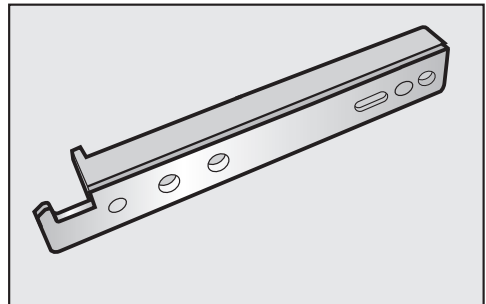

- Attach the correct left-hand spacer applicable to the thickness of the housing unit wall to one of the hooks supplied.
- Attach the other hook to the right-hand spacer.
- Before securing the hooks, make sure that the screws are fitted where the housing unit wall is at least 16 mm thick.

- Draw a line on both sides of the housing unit 420 mm above the floor of the housing unit.
- Position the lower edge of the spacer on this line and align the stopper at the front of the spacer with the front of the housing unit side wall.

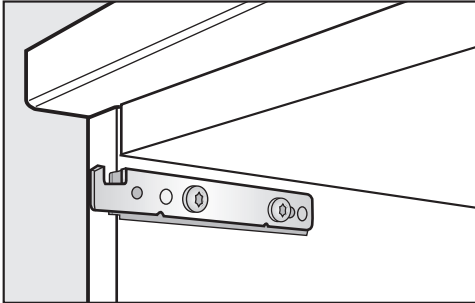

- To secure the spacers and hooks, place a screw in one of the front two holes and another in the middle of the long hole at the back. The long hole allows for adjustment if necessary; the two additional holes are provided in case additional screws are required.

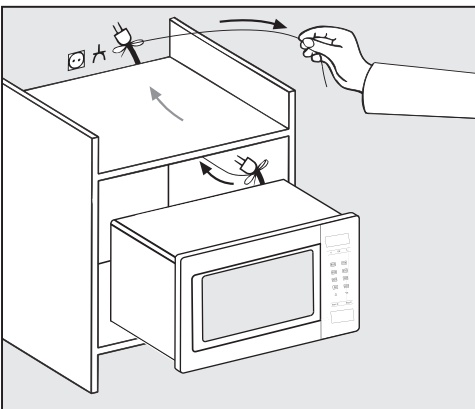

- Slide the appliance into the housing unit. Feed the cable with the plug through the back of the furniture unit.

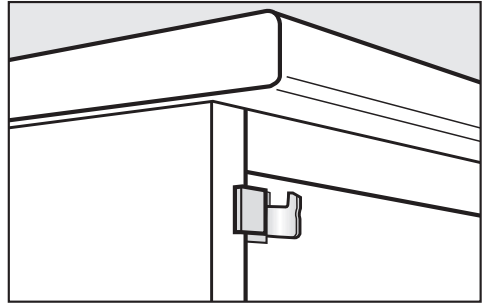

- Secure the appliance at the front by lifting it over the hooks and lowering it into position.
- Check that the appliance is secure by pushing lightly on the upper edge of the front frame.
- Check that it is correctly aligned.
- Connect the appliance to the electricity supply. Please refer to the instructions in the “Electrical connection” section of this manual for details regarding the connection of the appliance to the electricity supply.

Installation

Electrical connection

 Danger of injury due to a defective appliance.

Before connecting the appliance, ensure that it has not been damaged in any way.

Do not use a damaged appliance.

The appliance is supplied with a power cord and plug for connection.

Make sure that the earthed socket is freely accessible at all times. If the switch is not accessible after installation an additional means of disconnection must be provided for all poles.

 Risk of fire from overheating.

Connecting the appliance to a multi-socket plug adapter or to an extension lead can overload the cable.

Do not use an extension lead or multi-socket plug adapter.

Connect the appliance directly with the original cable without any intermediate elements.

The electrical system must comply with the applicable standards and with local and national regulations.

If the connection cable is damaged, it must only be replaced with a specific connection cable of the same type (available from Miele) in order to avoid a hazard. For safety reasons, such replacement may only be carried out by a qualified and competent technician or Miele.

The connection data can be found on the data plate located on the front of the oven interior or on the back of the appliance.

Compare the specifications on the data plate with those of the mains electricity supply. The data must match.

If in any doubt, consult a qualified electrician.

The appliance must not be connected to the inverter of an autonomous power supply such as e.g. a solar power system. When the appliance is switched on, power surges could result in a safety switch-off. This could damage the electronics.

The appliance must not be used with so-called energy saving devices either. These reduce the amount of energy supplied to the appliance, causing it to overheat.

Disposal of the packing material

The transport and protective packaging has been selected from materials which are environmentally friendly for disposal, and can normally be recycled.

Recycling the packaging reduces the use of raw materials in the manufacturing process and also reduces the amount of waste in landfill sites. Ensure that any plastic wrappings, bags etc. are disposed of safely and kept out of the reach of babies and young children. Danger of suffocation.

Disposing of your old appliance

Electrical and electronic appliances often contain valuable materials. They also contain specific materials, compounds and components, which were essential for their correct function and safety. These could be hazardous to human health and to the environment if disposed of with your domestic waste or if handled incorrectly. Please do not, therefore, dispose of your old appliance with your household waste.



Please dispose of it at your local community waste collection / recycling centre for electrical and electronic appliances. You are also responsible for deleting any personal data that may be stored on the appliance prior to disposal. Please ensure that your old appliance poses no risk to children while being stored prior to disposal.

Guide to the appliance

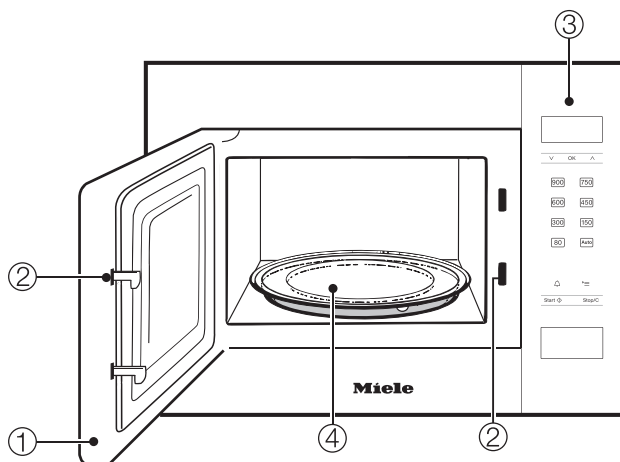

- ① Door
- ② Door lock
- ③ Control panel
- ④ Turntable

Control panel

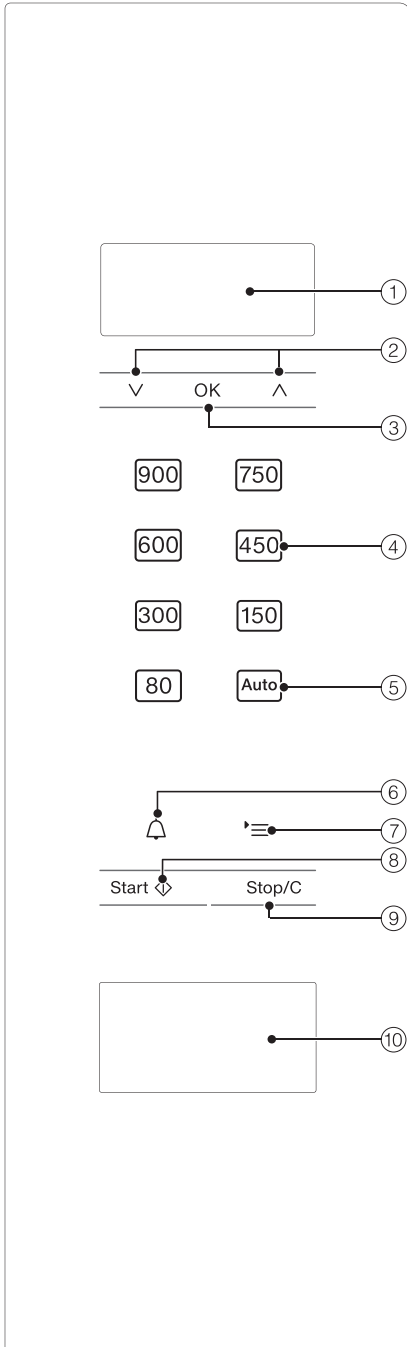

- ① For displaying the time of day and information on operation
- ② ^ and V arrow sensors for scrolling through lists and for changing values
- ③ OK sensor for selecting functions and saving settings
- ④ Different power levels of the microwave oven
- ⑤ Automatic programmes
- ⑥ Minute minder
- ⑦ ≡ sensor for selecting appliance settings
- ⑧ Start sensor/plus one minute/Quick MW
- ⑨ Stop/Cancel sensor
- ⑩ Door release

Description of the functions

In a microwave oven there is a high-frequency tube called a magnetron. This converts electrical energy into electromagnetic waves (microwaves). These microwaves are distributed evenly throughout the oven interior, and are reflected off the metal appliance walls. This enables the microwaves to reach the food from all sides and heat it up. Microwave distribution is improved with the turntable engaged.

In order for microwaves to reach the food, they must be able to penetrate the cooking container being used. Microwaves can pass through porcelain, glass, cardboard and plastics, but not metal. Therefore do not use utensils that are made of metal or contain metal, for example in the form of gold or silver trim. The metal reflects the microwaves and this could lead to the creation of sparks. The microwaves cannot be absorbed.

Microwaves pass through a suitable container and into the food. All food contains water molecules which, when subjected to microwave energy, start to oscillate 2.5 billion times a second. This vibration creates heat. It first starts developing around the outside of the food and then slowly penetrates towards the centre. The more water a food contains, the faster it is heated or cooked.

The heat is produced directly in the food. This has the following advantages:

- Food can generally be cooked without adding liquid or cooking oil, or with just a little water or oil.
- Cooking, reheating and defrosting in a microwave oven is quicker than using conventional methods.
- Nutrients, such as vitamins and minerals, are generally retained.
- The colour, texture and taste of food are not impaired.

Microwaves stop being produced as soon as the cooking process is interrupted or the appliance door is opened. When the appliance is in operation, the closed, sealed door prevents microwaves escaping from the appliance.

In the microwave oven, food is cooked, reheated or defrosted quickly.

You can use the microwave oven in the following ways:

– Food can be defrosted, reheated or cooked by entering a power level and a duration.

– Deep-frozen, ready-made meals can be defrosted and then heated or cooked.

– The microwave oven can also be used for other tasks, e.g. for proving yeast dough, melting chocolate and butter, dissolving gelatine, preparing cake icing, and preserving small amounts of fruit, vegetables and meat.

Functions

Microwave Solo mode

Suitable for defrosting, reheating and cooking.

Automatic programmes

You can choose from the following Automatic programmes:

- 5 defrosting programmes (A 1 to A 5)
- 3 cooking programmes for frozen food (A 6 to A 8)
- 3 cooking programmes for fresh food (A 9 to A 11)

These programmes are weight dependent, i.e. you enter the weight of the food and then the cooking duration is calculated automatically.

The weight of the food can be displayed as metric (g) or imperial (lb) (see “Changing settings”).

Suitable containers for microwave use

Microwaves

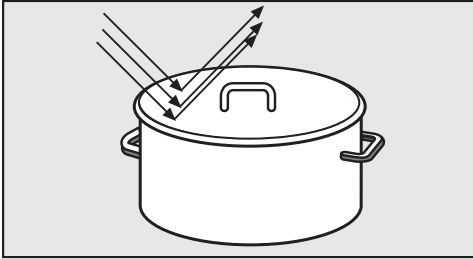

– are reflected by metal,

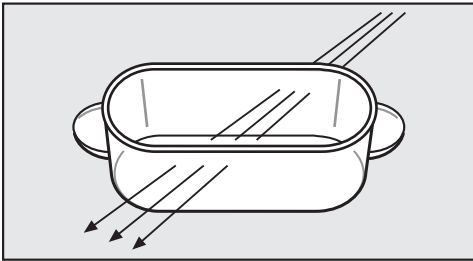

– pass through glass, porcelain, plastic and cardboard,

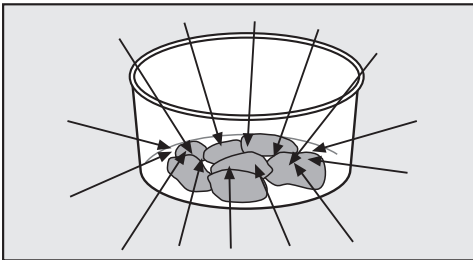

– and are absorbed by food.

⚠ Risk of fire due to unsuitable crockery.

Containers which are not suitable for use in microwave ovens can be badly damaged and cause damage to the appliance if used.

Please observe the information on suitable containers for microwave use.

Material and shape

The material and shape of containers used affect cooking results and times. Heat distribution is more even in round and oval shaped flat containers than in rectangular containers, providing better results.

⚠ Risk of injury due to hollow handle parts and lid knobs.

Moisture can penetrate hollow handles and lid knobs of crockery. This can lead to a build-up of pressure, which can cause the hollow parts to crack or shatter with the danger of injury.

Do not use crockery with hollow handles or lid knobs, unless the hollow parts are sufficiently vented.

Metal

Metal containers, aluminium foil, metal cutlery, and china with metallic decoration such as gold rims or cobalt blue must not be used with microwave mode. Metal reflects microwaves and obstructs the cooking process.

Do not use containers where the foil lid has not been completely removed as small pieces of foil can cause sparking.

Exceptions:

– Ready-meals in aluminium foil dishes

These can be defrosted and reheated in the microwave oven, if recommended by the manufacturer. Important: Remove the lid and make sure the foil dish is at least 2 cm from the oven walls at all times. However, food is only

Suitable containers for microwave use

heated from the top. Transferring the food from the aluminium foil container to a dish suitable for microwave use will result in a more even heat distribution.

Do not place aluminium foil dishes in the microwave, as sparks and arcing can occur. If this occurs, transfer food to a microwave-safe container.

- Pieces of aluminium foil

For even defrosting and to avoid overcooking unevenly shaped cuts of meat, poultry or fish, small pieces of aluminium foil may be used to mask wingtips or other thin parts for the last few minutes of the programme.

Make sure that the aluminium foil is at least 2 cm from the oven walls at all times. It must not touch the walls.

- Metal meat skewers or clamps

These should only be used if they are very small in comparison to the size of the cut of meat.

Glazes and colours

Some dishes have glazes and colours containing metallic substances. These dishes are unsuitable for microwave use.

Glassware

Heat-resistant glass or ceramic glass is ideal for use in the microwave oven.

Crystal glass is unsuitable as it usually contains lead which could cause the glass to crack in the microwave.

Porcelain

Porcelain is a suitable material.

However do not use porcelain with gold or silver edging, or items with hollow knobs or handles.

Earthenware

Decorated earthenware is only suitable if the decoration is beneath an all-over glaze.

Earthenware can get very hot and may crack.

Wear oven gloves when removing the dishes from the oven.

Wood

Water contained in wood evaporates during the cooking programme. This causes the wood to dry and crack.

Wooden dishes are therefore not suitable.

Plastics

 Damage caused by heat-sensitive plastics.

Plastics must be heat-resistant to a minimum of 110 °C. Otherwise the plastic may melt and fuse with the food.

Use plastic containers only with Microwave Solo mode.

Special plastic utensils designed for use in microwave ovens are available from retail outlets.

Melamine containers are not suitable. They absorb energy and become hot. When purchasing plasticware, make sure that it is suitable for use in a

Suitable containers for microwave use

microwave oven.
Disposable containers, such as trays made from polystyrene, can only be used for very short, timed warming and reheating of food.

To protect the environment we do not recommend the use of single-use containers.

Plastic boiling bags can be used for cooking and reheating. They should be pierced beforehand to allow the steam to escape. This prevents a build-up of pressure from forming and the bag from bursting.

There are also special bags available for steam cooking which do not need to be pierced. Please follow the instructions given on the packet.



Risk of fire due to unsuitable material.

Do not use metal clips, plastic clips containing metal parts, or paper ties containing wire.

There is a danger that they will ignite when heated.

Disposable containers

Disposable plastic containers must have the characteristics listed under “Plastics”.



Risk of fire due to unsuitable crockery.

Disposable containers made out of plastic, paper or other inflammable materials can ignite.

Do not leave the appliance unattended when reheating or cooking food in disposable containers made of plastic, paper or other inflammable materials.

Suitable containers for microwave use

Testing containers

If in doubt as to whether glass, earthenware or porcelain plates or dishes are suitable for use in a microwave oven, a simple test can be performed:

- Place the item you wish to test in the centre of the oven.
- Close the door.
- Select the maximum power setting.
- Confirm the flashing 0 for the minutes with *OK*.
- Enter 30 seconds using the \wedge and \vee arrow sensors and confirm the entry with *OK*.
- Touch the Start sensor.

If a crackling noise is heard during the test accompanied by sparks, switch the appliance off immediately (touch Stop/C twice)! Any crockery which causes this reaction is unsuitable for use with microwave power. If any doubt exists about the suitability of containers, please contact the manufacturer or supplier.

This test cannot be used to check whether items with hollow knobs or handles are suitable for use in a microwave oven.

A microwave lid or cover

- prevents too much steam escaping, especially when cooking foods which need longer to cook, such as potatoes.
- speeds up the cooking process.
- prevents food from drying out.
- helps keep the oven interior clean.

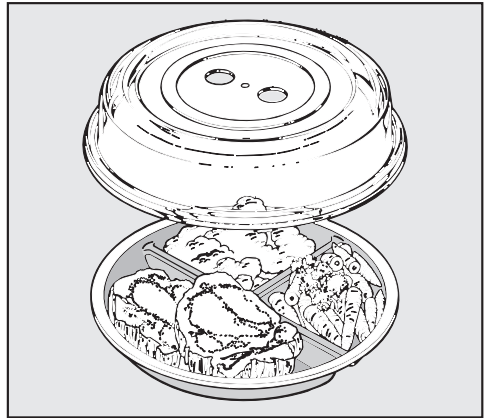

- When using Microwave Solo, always cover food with a microwave-safe lid.

Suitable covers are available from retail outlets.

Alternatively, you can use lids or covers made of microwave-safe glass or plastic, or cling film recommended for use in a microwave oven by the manufacturer. Normal cling film may distort with the heat and fuse with the food.

Suitable containers for microwave use

 Damage caused by heat-sensitive plastics.

The material of the microwave cover must be able to withstand temperatures of up to 110 °C (see manufacturer information). At higher temperatures the plastic may distort and fuse with the food.

Therefore the cover must only be used in microwave ovens and only with Microwave Solo mode.

 Damage due to covered openings.

If a lid is used with a container which only has a narrow diameter, the cover could form a seal around the container and there might not be enough room for condensation to escape through any holes in the top. The cover could get too hot and start to melt.

Make sure that the cover does not form a seal.

 Risk of explosion due to pressure build-up.

Pressure can build up when reheating food or drinks in sealed containers, jars or bottles, which can cause them to explode.

Sealed glass containers, such as jars of baby food, must be opened before they are placed in the microwave oven. Do not attempt to heat them up unopened. With baby bottles, the screw top and teat must be taken off.

Do not use a lid or cover when

- cooking food coated with breadcrumbs.
- cooking meals which are to be given a crisp finish, such as toast.

Before using for the first time

The appliance must be built in before it can be used.

The changed time is adopted.

When the microwave is connected to the mains electricity, it is immediately ready for use.

Setting the time of day

- Connect the appliance to the electricity supply.

12:00 will appear in the display. The digits before the colon will flash.

- Use the \wedge and \vee arrow sensors to set the hours.
- Confirm with *OK*.
- Use the \wedge and \vee arrow sensors to set the minutes.
- Confirm with *OK*.

The set time is now adopted.

You can switch between the 24-hour and 12-hour format (1=pm) (see “Changing settings”).

The time of day display can be set to switch itself off every night from 11:00 pm until 5:00 am (See “Changing settings”).

Altering the time of day

- Touch the \equiv sensor.

P1 will appear in the display.

- Touch *OK*.
- Use the arrow sensors to change the hour and confirm with *OK*.
- Use the arrow sensors to set the minutes and confirm with *OK*.

Operation

Opening the door

- Press the door release button to open the door.

If the microwave oven is in operation, opening the door will interrupt the cooking programme.

Placing a dish in the oven

Ideally the dish should be placed in the middle of the oven compartment.

Turntable

If fixed and built-in appliances are used at a height of 900 mm or higher above the floor, care should be taken not to displace the turntable when removing containers from the appliance.

The turntable helps the food to cook, reheat or defrost evenly.

Do not operate the microwave without the turntable in place.

The turntable starts turning automatically when the appliance is operated.

Do not cook, reheat or defrost food directly on the turntable. Check that the dish is not larger in size than the turntable.

Turn or stir food during cooking, or turn the dish so that it heats up evenly.

Closing the door

- Push the door firmly shut.

Touch the Start sensor to resume an interrupted cooking programme.

The appliance will not start again if the door has not been closed properly.

Starting a programme

The microwave power level is selected by touching the corresponding sensor control.

- Touch the sensor for the required power level.

 and the microwave power level will light up in the display.

- Use the arrow sensors to set the required cooking duration, starting with the minutes, and confirm your selection with *OK*.
- Then set the seconds and confirm again with *OK*.
- Touch the *Start* sensor.

The cooking programme starts.

You can choose between 7 power levels.

The higher the power level, the more microwaves reach the food.

When heating up food which cannot be stirred or turned during cooking, as with a plated meal, it is best to use a lower microwave power level.

This ensures the heat is distributed evenly. Heat for long enough to cook the food properly.

You can set a duration of up to 90 minutes. Exception: If the maximum microwave power level has been selected, a maximum cooking duration of 15 minutes can be set. If you continue to use the maximum power,

the power level may be reduced, and this is shown in the display (protection against overheating).

The time required depends on:

- the initial temperature of the food.
Food taken straight from the refrigerator takes longer to cook than food which has been kept at room temperature.
- the type and texture of the food.
Fresh vegetables contain more water and cook more quickly than stored vegetables.
- the frequency of stirring or turning the food.
Frequent stirring or turning heats the food more evenly, and it is therefore ready in a shorter time.
- the amount of food.
As a general rule, allow approx. time and a half for double the quantity.
For a smaller quantity, shorten the duration accordingly.
- the shape and material of the container.

“door” message

The “door” message in the display is a reminder that the appliance should not be used without food inside it.

Operating the appliance without food can damage the appliance.

If the Start sensor is touched without the door having first been opened, the word **door** appears in the display. If the door has been closed for 20 minutes or longer, it could mean that there is no food in the microwave oven. This is to

remind you to open the door and make sure there is food in the microwave oven before starting a cooking process. Start is blocked until the door is opened.

Interrupting or restarting a programme

At any time you can . . .

. . . **interrupt a programme:**

- Touch the Stop/C sensor or open the appliance door.

The time stops counting down.

. . . **continue a programme:**

- Close the door and touch Start.

The programme will continue.

Altering the settings

If you discover after starting a programme that . . .

. . . the **microwave power level** is too high or too low, you can

- select a new level.

. . . the **duration** set is too short or too long, you can

- interrupt the programme (touch the Stop/C sensor once), use the arrow sensors to set a new time and continue the programme (touch the Start sensor).

Or alternatively:

- The cooking duration can be increased by touching Start during operation. Each time Start is touched, the cooking duration is increased by another minute (exception: the cooking time increases in increments

Operation

of 30 seconds when the microwave is being used at the maximum power level).

Cancelling a programme

- Touch the Stop/C sensor twice.

At the end of a programme

A signal tone will sound when the cooking programme is complete. The interior lighting goes out.

The signal tone will sound briefly as a reminder every 5 minutes for 20 minutes after the end of the programme.

- If you want to stop the signal tone, touch the Stop/C sensor.

Automatic keeping warm function

The keeping warm function will switch on automatically after the end of a cooking programme which has used at least 450 W, providing the door remains closed and no sensors are touched. After approx. 2 minutes the keeping warm function will switch on at 80 W for a maximum period of 15 minutes.

, 80 W and **H:H** will light up in the display.

Opening the door or operating one of the sensors while the keeping warm function is in progress cancels the function.

The keeping warm function cannot be set separately.

You can deactivate this function (see “Changing settings”).

Quick microwave

Touching the Start/ sensor is sufficient to set the appliance operating at maximum power for one minute.

- Touch the Start/ sensor.

If no further selection is made, the microwave will operate at maximum power for one minute.

The cooking duration can be increased by touching Start during operation. Each time it is touched, the cooking duration is increased by another 30 seconds.

Changing the duration and power level

You can change the preset duration and power level and save this as one of your main applications.

At the 300 W power level a maximum duration of 10 minutes can be saved. From 450 W a maximum duration of 5 minutes can be saved.

- Touch the  sensor.

P1 will appear in the display.

- Use the arrow sensors to select P 8.

- Confirm your selection with *OK*.

- Change the power level and confirm with *OK*.

- Change the duration and confirm with *OK*.

- If you do not want to change a setting, touch the *OK* sensor.

- When you have finished changing appliance settings, touch the Stop/C sensor.

The altered settings are retained after a power cut.

System lock

The system lock prevents the appliance being used unintentionally, for example by children.

Activating the system lock

- Touch and hold the *OK* sensor with the seconds counting down from 6 until a signal tone sounds and the key symbol appears in the display:



The key symbol will go out after a short time.

All functions are now locked. Only the minute minder can be used when the system lock is activated (see “Using the minute minder”).

After an interruption to the power supply, the system lock must be activated again.

Deactivating the system lock

- To deactivate the system lock, touch the *OK* sensor again and hold it until the signal tone sounds.

Operation

Using the minute minder

The minute minder can be used to time any activity in the kitchen, e.g. boiling eggs. The set time counts down in seconds.

- Touch the  sensor.
- Use the arrow sensors to set the minutes for the minute minder and confirm with *OK*.
- Then set the seconds for the minute minder and confirm with *OK*.

 lights up in the display and the time is counting down.

After the time has elapsed, a signal tone will sound which is repeated several times.

 flashes and the time counts up. This enables you to see how long ago the minute minder time elapsed.

- Touch the  sensor to stop the process.

Altering a minute minder entry

- Touch the  sensor.

The current minute minder countdown is stopped.

- Use the arrow sensors to change the minute minder time and confirm with *OK*.

The minute minder continues to count down.

Cancelling the minute minder

- Touch the Stop/C sensor.

The current minute minder is deleted.

Minute minder + cooking process

The minute minder can be used at the same time as a cooking process and counts down in the background.

- Touch the  sensor during the cooking programme.
- Use the arrow sensors to set the required minute minder and confirm with *OK*.

A few seconds later, the display will revert back to showing the cooking duration counting down. The minute minder time counting down in the background is represented by the illuminated  symbol.

If you touch the  sensor during the cooking process, the minute minder time still remaining will be shown in the display.

Operation - Automatic programmes

All of the Automatic programmes are weight dependent.

The weight of the food can be displayed as metric (g) or imperial (lb) (see “Changing settings”).

After selecting a programme, enter the weight of the food. The appliance automatically calculates the duration according to the weight entered.

After cooking, allow the food to stand at room temperature for the suggested number of minutes (“standing time”) to allow the heat to be distributed evenly through the food.

Automatic defrosting

There are five programmes for defrosting different types of food. The standing time for programme A 3 is up to 30 minutes, depending on weight, and approx. 10 minutes for the remaining programmes.

A 1 
Steak, chops

A 2 
Minced meat

A 3 
Chicken

A 4 
Cakes

A 5 
Bread

This programme is particularly suitable for defrosting frozen sliced bread. If possible, place single slices in the microwave, or separate the slices when the signal tone sounds at half-time.

Automatic cooking

There are three programmes each for frozen and for fresh food.

The standing time for each of these programmes is approx. 2 minutes.

Cooking food from frozen

A 6 
Vegetables

A 7 
Ready meals which can be stirred

A 8 
Bakes, gratin

Cooking fresh food

A 9 
Vegetables

A 10 
Potatoes

A 11 
Fish

Using an Automatic programme

- Touch the  sensor.
- Use the arrow sensors to select the desired Automatic programme from the list.
- Confirm your selection with *OK*.

The display shows  for microwave and the lowest weight of the food for the selected programme.

The  start symbol and g or lb will flash to request the entry of the weight.

- Use the arrow sensors to enter the correct weight of the food.
- Start the programme.

Operation - Automatic programmes

The cooking duration which corresponds to the weight begins to count down, and the microwave symbol  lights up.

A signal tone will sound halfway through the cooking duration.

- Interrupt the programme to turn or stir the food, and then continue the programme.

If necessary, the programmed time can be extended by a few minutes during operation by touching Start repeatedly until the time required appears in the display. In all programmes it is only possible to extend the time by a few minutes.

A signal tone will sound when the cooking programme is complete. The interior lighting goes out.

Recipes - Automatic programmes

Below are some recipe suggestions for the “Cooking fresh food” Automatic programmes. These can be adapted to suit your requirements.

If the weight specifications are exceeded, the food will not cook sufficiently.

It is important to follow the weight guidelines given for each programme.

A 9 Vegetables

Preparation

Place the prepared vegetables in a container. Add 1 ½-2 tbsp. water, depending on freshness and moisture content, and a little salt or other seasoning. Enter the weight including that of the water, place the covered cooking container on the turntable and cook. About halfway through the cooking duration, a signal tone will sound to prompt you to turn or stir the food.

When cooking vegetables in a sauce, the weight entered must include the sauce. Do not exceed the maximum weight guidelines.

Carrots in a chervil cream sauce (serves 2)

Preparation time: 25 – 35 minutes

Ingredients

350 g carrots, cleaned
5 g butter
50 ml vegetable stock (instant)
75 ml crème fraîche
1 tbsp. white wine
Salt and pepper
1 pinch of sugar
½ tsp. mustard
1-2 tbsp. chervil, fresh, chopped or
1 tbsp. chervil, dried and ground
Approx. 1 tbsp. cornflour

Method

Peel carrots, then cut into batons or slices (approx. 3 – 4 mm thick). Combine the rest of the ingredients, and pour over the carrots. Cover and cook. Stir when the signal tone sounds.

Setting: Cooking fresh food A 9 

Weight: 525 g

Shelf level: Turntable

Recipes - Automatic programmes

Golden curried potatoes (serves 3)

Preparation time: 25 – 35 minutes

Ingredients

500 g peeled potatoes
1 onion, finely diced
10 g butter
1 – 2 tbsp. curry powder
250 ml vegetable stock (instant)
50 ml double cream
125 g peas (frozen)
Salt and pepper

Method

Coarsely dice the potatoes (approx. 3 x 3 cm) or use small potatoes. Mix together all the ingredients in a suitably large dish. Cover and cook. Stir when the signal tone sounds, then continue cooking.

Setting: Cooking fresh food A 10 

Weight: 800 g

Shelf level: Turntable

A 11 Fish: Fish curry (serves 4)

Preparation time: 35 – 45 minutes

Ingredients

300 g pineapple chunks
1 red capsicum
1 small banana
500 g firm white fish
2 tbsp. lemon juice
30 g butter
100 ml white wine
100 ml pineapple juice
Salt, sugar and chilli powder
2 tbsp. cornflour

Method

Dice the fish and place in a suitable container. Drizzle with lemon juice. Quarter the capsicum, remove the seeds and pith, and cut into narrow strips. Peel and slice the banana. Add to the fish along with the capsicum and pineapple pieces, and mix well. Add the butter. Mix together the wine, juice, seasoning and cornflour to make a smooth sauce and pour over the fish. Mix everything thoroughly, then cover and cook.

Setting: Cooking fresh food A 11 

Weight: approx. 1200 g

Shelf level: Turntable

You can select an alternative for some settings of your appliance.

Please consult the chart for the individual settings that can be changed. The factory settings are marked with an asterisk * in the chart.

To change a setting, proceed as follows:

- Touch the '≡ sensor.
- P1 will appear in the display.
- Use the arrow sensors to select the setting you wish to change.
- Confirm your selection with *OK*.
- Depending on the appliance setting, you can now use the arrow sensors to enter values or select setting options.
- Select *OK* if you do not want to change a setting and wish to switch to another.
- When you have finished changing settings, touch the *Stop/C* sensor.

The altered settings are retained after a power cut.

Changing settings

Setting		Settings available (* factory setting)	
P 1	Setting the time of day	Hours	Enter the hours with the arrow sensors.
		Minutes	Enter the minutes with the arrow sensors.
P 2	Signal tones	5 0	Signal tones are switched off.
		5 1 *	Signal tones are switched on.
P 3	Keypad tone	5 0	Keypad tone is deactivated.
		5 1 *	Keypad tone is activated.
P 4	Clock format	24 h	24 hour display is activated.
		12 h	12 hour display is activated.
P 5	Night time switch-off	5 0 *	Night time switch-off is deactivated.
		5 1	Night time switch-off is activated. The time of day display is switched off between the hours of 11:00 pm and 5:00 am.
P 6	Weight unit	5 0 *	Food weight is displayed in grams (g).
		5 1	Food weight is displayed in pounds (lb).
P 7	Automatic keeping warm function	5 0	The automatic keeping warm function is deactivated.
		5 1 *	The automatic keeping warm function is activated.
P 8	Quick MW	Power level	The maximum power level can be changed.
		Duration	The duration of 1 minute can be changed.
P 9	"door" message	5 0	The "door" message does not appear.
		5 1 *	The "door" message appears if the door has not been opened in the last 20 minutes. Start is blocked.

Changing settings

Setting		Settings available (* factory setting)	
<i>P 10</i>	Demo mode (for showroom use only)	<i>S 0*</i>	Demo mode is deactivated. When demo mode is deactivated, _ _ _ _ appears briefly in the display.
		<i>S 1</i>	Demo mode is activated. When a sensor or selector is operated, <i>RES_</i> appears briefly in the display. The appliance cannot be operated.
<i>P 0</i>	Factory default settings	<i>S 0</i>	Factory default settings have been changed.
		<i>S 1*</i>	Factory default settings have been restored, or have not been changed.

Reheating

Select the following microwave power levels to reheat food:

Drinks	900 W
Food	600 W
Food for babies and children	450 W

 Risk of burning due to hot food. Food for babies and children must not be too hot. Reheat it for only 1/2 to 1 minute at 450 W.

Tips on reheating

Always use a lid or cover for reheating food, except when a crispy finish is required, e.g. crumbed poultry/meat.

 Risk of explosion due to pressure build-up. Pressure can build up when reheating food or drinks in sealed containers, jars or bottles, which can cause them to explode. Sealed glass containers, such as jars of baby food, must be opened before they are placed in the microwave. Do not attempt to heat them up unopened. With baby bottles, the screw top and teat must be taken off.

 Risk of injury from boiling liquids. When heating liquids, milk, sauces etc. using microwave power, the boiling point of the liquid may be reached without the production of the typical bubbles. Liquids do not boil evenly throughout. This so-called 'boiling delay' can cause a sudden build-up of bubbles when the container is removed from the oven or shaken, which can lead to the liquid boiling over suddenly and explosively. The formation of bubbles can be so strong that the pressure forces the oven door open.

Flash boiling can be avoided by stirring liquids before heating them. After heating, wait at least 20 seconds before removing the container from the oven. In addition, a glass rod or similar item, if available, can be placed in the container during heating.

Eggs can explode. Never reheat hard boiled eggs in the microwave, even without the shell.

Food taken straight from the refrigerator takes longer to reheat than food which has been kept at room temperature. The reheating time required depends on the nature of the food, its initial temperature and the amount to be cooked.

Always ensure that food is sufficiently cooked or reheated.

If in any doubt that a sufficiently high temperature has been reached, continue reheating for a little longer.

Stir or turn larger amounts of food from time to time during reheating. Stir the food from the outside towards the middle, as food heats more quickly around the outside.

After reheating

Be careful when removing the dish from the oven. It may be hot.

Although heat is not normally produced in the container itself by the microwaves (apart from stoneware), heat transfer from the food to the container may be considerable, making the container itself hot.

Allow food to stand for a few minutes at room temperature at the end of cooking. This enables the heat to spread evenly through the food.

 Risk of burning due to hot food.

The food can be very hot after reheating.

After reheating food, especially food for babies and small children, stir the food or shake the container and check that the temperature does not pose any danger.

Cooking

Place the food in a microwave-proof dish and cover it.

When cooking, it is a good idea to select a power level of 900 W to start with, and when the food is hot reduce the power level to 450 W for more gentle continued cooking.

For dishes such as **rice pudding** or **semolina pudding**, first select a power level of 900 W, and then reduce it to 150 W for simmering.

Tips on cooking

Vegetable cooking durations depend on the texture of the vegetables. Fresh vegetables contain more water than vegetables which have been stored, and usually cook more quickly. Add a little water to vegetables which have been kept stored.

Food taken straight from the refrigerator takes longer to cook than food which has been kept at room temperature.

Stir or turn food from time to time during cooking. This helps it cook more evenly.

 Health risk due to cooking time being too short.

It is very important to make sure that food which goes off easily, such as fish, is cooked for a sufficient time. When cooking these types of food, ensure that the stated cooking durations are observed.

Food with a thick skin or peel, such as tomatoes, sausages, jacket potatoes and aubergines, should be pierced or

the skin scored in several places before cooking to allow steam to escape and to prevent the food from bursting.

 Risk of injury from eggs with shells.

Eggs heated in their shells can burst, even after they have been taken out of the oven.

Eggs can only be cooked in their shells in the microwave oven in a specially designed egg-boiling device available from specialist shops.

 Risk of burning from eggs without shells.

If you cook eggs without their shells using microwave power, the yolks could explode due to the resulting pressure.

Eggs can be cooked without their shells in the microwave oven only if the yolk membrane has been punctured several times first.

After cooking

Be careful when removing the dish from the oven. It may be hot.

Although heat is not normally produced in the container itself by the microwaves (apart from stoneware), heat transfer from the food to the container may be considerable, making the container itself hot.

Allow food to stand for a few minutes at room temperature at the end of cooking. This enables the heat to spread evenly through the food.

 Health risk due to refreezing. Thawed or defrosted food loses nutritional value through refreezing and can go off.

Do not refreeze food once it has thawed. Use it as quickly as possible. Defrosted food may only be refrozen after it has been cooked.

Select the following microwave power settings to defrost food:

- 80 W
for defrosting very delicate food, e.g. cream, butter, gateau and cheese.
- 150 W
for defrosting other types of food.

Remove the food from its packaging and place in a microwave-proof container. Defrost uncovered. Turn, stir or separate the food about halfway through the defrosting time.

To defrost meat, unpack the frozen meat and place it on an upturned plate in a glass or porcelain container so that the meat juice can run off and be collected. Turn halfway through defrosting.

 Health risk due to risk of salmonella.

It is particularly important to observe food hygiene rules when defrosting poultry.

Do not use the liquid produced during defrosting.

Meat and poultry need to be fully defrosted before cooking. Fish, on the other hand, can be partially

defrosted before cooking. Defrost so that the surface is sufficiently soft to take herbs and seasoning.

Defrosting and cooking

Deep-frozen food can be defrosted and immediately heated or cooked.

First select 900 W followed by 450 W.

Remove the food from its packaging and place in a covered microwave-proof dish for defrosting and reheating or cooking. Exception: Minced meat should be left uncovered while cooking.

Food with a high water content such as soup, stew and vegetables should be stirred several times during the process. Carefully separate and turn slices of meat halfway through the programme. Turn pieces of fish at the halfway stage.

After defrosting and reheating or cooking allow the food to stand at room temperature for a few minutes to enable the heat to spread evenly through the food.

Bottling

You can preserve small portions of fruit, vegetables and meat in microwave-safe jars that are available from specialist retailers. Prepare the jars in the usual way.

Fill the jars no more than up to 2 cm below the rim.

Seal the microwave-safe preserving jars with clear adhesive tape or clips suitable for microwave use.

Never use metal clips, jars with screw-on lids or cans in order to prevent sparking.

For best results do not use more than four $\frac{1}{2}$ - litre jars at a time when bottling.

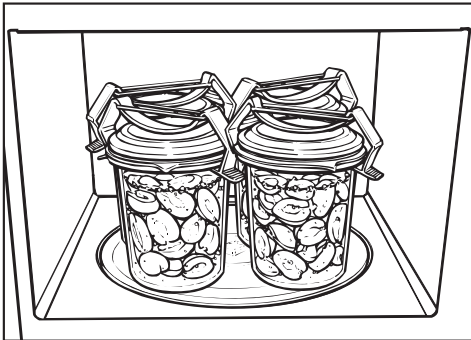

- Place the jars on the turntable.
- Set to 900 W and bring the jar contents to the boil.

The time required depends on:

- the initial temperature of the contents.
- the number of jars.

The amount of time required for the contents in all jars to start bubbling evenly is as follows:

1 jar	approx. 3 minutes
2 jars	approx. 6 minutes
3 jars	approx. 9 minutes
4 jars	approx. 12 minutes

This is sufficient time for bottling fruit and cucumbers.

For vegetables, reduce the power to 450 W once the produce starts boiling. Cook

- carrots for approx. 15 minutes
- peas for approx. 25 minutes.

After bottling

Remove jars from the oven, cover with a towel and leave to stand in a draught-free location for approx. 24 hours.

Remove the clips or the adhesive tape and make sure that all jars are sealed properly.

Examples of use

Food	Quantity	MW power level (W)	Duration (in minutes)	Notes
Melting butter/margarine	100 g	450	1:00 – 1:10	Do not cover
Melting chocolate	100 g	450	3:00 – 3:30	Do not cover, stir halfway through melting
Dissolving gelatine	1 packet + 4 tbsp. water	450	00:10 – 00:30	Do not cover, stir halfway through dissolving
Preparing flan topping/jelly glaze	1 packet + 250 ml liquid	450	4 – 5	Do not cover, stir halfway through heating
Yeast dough	Starter dough made with 100 g flour	80	3 – 5	Cover and leave to prove
Making popcorn	1 tbsp. (20 g) popcorn	900	3 – 4	Place popcorn in a 1 litre container, cover and cook, sprinkle with sugar or salt after cooking
Chocolate marshmallows	20 g	600	00:10 – 00:20	Place on a plate, do not cover
Steeping oil for salad dressing	125 ml	150	1 – 2	Heat uncovered on gentle heat
Tempering citrus fruits	150 g	150	1 – 2	Place on a plate, do not cover
Cooking bacon	100 g	900	2 – 3	Place on kitchen paper, do not cover
Softening ice cream	500 g	150	2	Place open container in the appliance
Skinning tomatoes	3 tomatoes	450	6 – 7	Cut a cross into the top of each tomato, cover, and heat in a little water. The skins will slip off easily. Take care, as the tomatoes can get very hot.

Examples of use

Food	Quantity	MW power level (W)	Duration (in minutes)	Notes
Making strawberry jam	300 g strawberries, 300 g jam sugar	900	7 – 9	Mix the fruit and sugar in a deep container, cover and cook.

The information given in this chart is intended only as a guide.

Disconnect the microwave oven from the power supply before cleaning.

Under no circumstances should a steam cleaner be used to clean the microwave oven. The steam could reach live electrical components and cause a short circuit.

Oven interior and inside of the door

 Risk of burning due to hot oven compartment. The oven compartment may be too hot to clean immediately after use. Clean the oven interior once it has cooled down.

 Fire hazard due to excessive soiling. Excessive soiling could damage the appliance in certain circumstances and could even be dangerous due to the fire risk. Do not wait too long to clean the appliance as this will make cleaning unnecessarily difficult and in extreme cases, impossible.

The microwave oven interior and door interior can be cleaned using a damp cloth with a little washing-up liquid or a mild detergent and water. Wipe dry with a soft cloth.

For more heavy soiling, heat a glass of water for 2 to 3 minutes until the water begins to boil. The steam will collect on the walls and soften the soiling. The

oven interior can now be wiped clean using a little washing-up liquid if necessary.

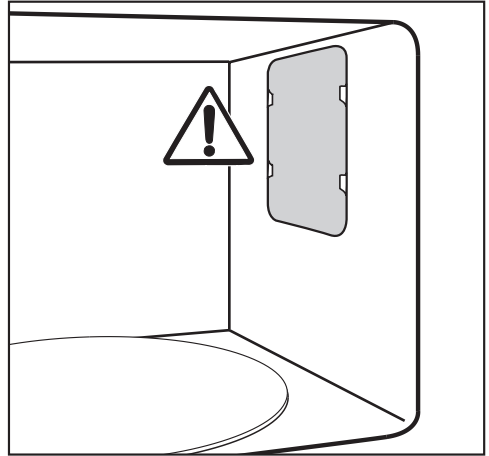

Do not remove the cover of the microwave outlet inside the oven, nor the film covering the inside of the door.

Do not let water or any object find its way into or block the air vents of the appliance. Do not use too much water on the cloth or sponge, otherwise water may get into openings. Do not use scouring agents. These will scratch.

To neutralise odours in the microwave oven, put a cup of water with some lemon juice in the appliance and simmer for a few minutes.

Cleaning and care

 Danger to health due to a defective device.

If any damage to the door or the door seals is noticed, the appliance must not be used until the fault has been repaired by a Miele authorised service technician. Operating a damaged appliance can result in microwave leakage and present a hazard to the user.

The door should be kept clean at all times and checked at regular intervals for any signs of damage. Do not use the appliance if

- the appliance door is warped.
- the door hinges are loose.
- holes or cracks are visible in the casing, the door or the oven interior walls.

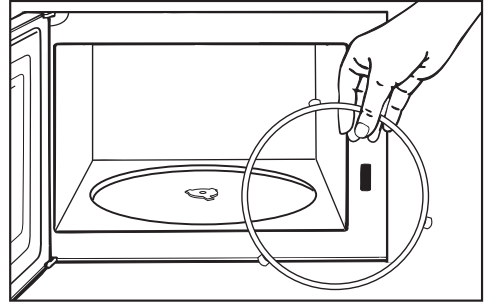

- Always keep the roller ring underneath it and the oven floor clean. Otherwise the turntable will not turn smoothly.
- Clean the area between the turntable and the roller ring.

Do not turn the turntable and/or carrier manually, as this could damage the drive motor.

To clean the interior:

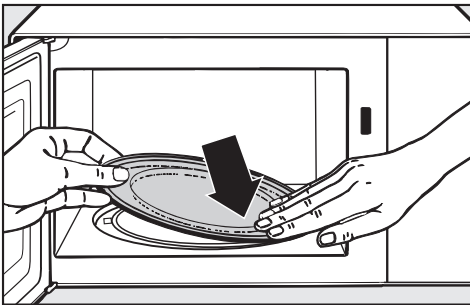

- Remove the turntable, and wash in the dishwasher or by hand.

Appliance front

Do not let water or any small particles penetrate the vents in the appliance.

Soiling that is left too long might become impossible to remove and could cause external surfaces to alter or discolour.

Remove any soiling on the front of the appliance straight away.

Clean the front with a soft sponge and a solution of warm water and a little washing-up liquid. Wipe dry using a soft cloth.

A clean, damp microfibre cloth without cleaning agent can also be used.

All surfaces of this appliance are susceptible to scratching. Scratches on glass surfaces could cause a breakage in certain circumstances. Contact with unsuitable cleaning agents can alter or discolour all surfaces.

Please observe the following cleaning instructions.

To avoid damaging the surfaces of the appliance, do not use:

- cleaning agents containing soda, ammonia, acids or chlorides
- cleaning agents containing descaling agents
- abrasive cleaning agents, e.g. powder cleaners and cream cleaners
- solvent-based cleaning agents
- stainless steel cleaning agents
- dishwasher cleaner
- oven sprays
- glass cleaning agents
- hard, abrasive sponges and brushes, e.g. pot scourers
- dirt erasers
- sharp metal scrapers.

Problem solving guide

With the help of the following guide, minor faults in the performance of the appliance, some of which may result from incorrect operation, can be remedied without contacting Miele. This will save you time and money because you won't need a service call.

Please note that a call-out charge will be applied to unnecessary service visits where the problem could have been rectified as described in these operating instructions.

Problem	Possible cause and remedy
A programme will not start.	Check whether <ul style="list-style-type: none">■ the appliance door is closed properly.■ the system lock has been activated (see “System lock”).■ “door” has appeared in the display. The door has remained closed for 20 minutes or longer after the last cooking process (see “Operation - door message”).■ the appliance is plugged into the mains supply and switched on at the socket.■ the mains circuit breaker has tripped. If it has, there could be a fault with the appliance, the household electricity supply or another appliance (disconnect the appliance from the electricity supply and contact a qualified electrician or Miele, see “After sales service”).
A noise can be heard after a cooking process.	This is not a fault. The cooling fan will continue to run for a while after a cooking programme to prevent any humidity building up in the oven, on the control panel or the oven housing unit. It will switch off automatically.
The display is dark.	It is between 11:00 pm and 5:00 am and the night time switch-off is activated. <ul style="list-style-type: none">■ If you want to be able to read the time of day at all times, switch off the night time switch-off.
The turntable does not turn smoothly.	The area underneath the turntable could be dirty. <ul style="list-style-type: none">■ Check whether the oven floor underneath the turntable is clean.■ Check whether the surfaces between the turntable and the roller ring are clean.■ Clean the area underneath the turntable.

Problem solving guide

Problem	Possible cause and remedy
<p>Food is not adequately defrosted, heated or cooked at the end of the selected cooking duration.</p>	<p>The duration or power level were insufficient to cook the food.</p> <ul style="list-style-type: none"> ■ Check whether the correct power level was selected for the duration set. The lower the power level, the longer the duration required. ■ Check whether the programme has been interrupted and not restarted.
<p>The microwave operation works but not the lighting.</p>	<p>The lamp needs to be replaced. You can operate the appliance as normal, but without the lighting.</p> <ul style="list-style-type: none"> ■ Contact Miele if you need to replace the lamp.
<p>Strange noises are heard when the microwave oven is being used.</p>	<p>The food is covered with aluminium foil.</p> <ul style="list-style-type: none"> ■ Remove the aluminium foil.
	<p>Sparks are being created by the use of crockery with a metallic finish.</p> <ul style="list-style-type: none"> ■ Please observe the information on suitable containers for microwave use.
<p>The time of day in the display is not accurate.</p>	<p>If there has been a power cut, the time automatically switches back to 12:00. The time of day needs to be reset.</p> <ul style="list-style-type: none"> ■ Set the correct time of day.
<p>Food cools down too quickly.</p>	<p>In a microwave oven, food begins to cook from the outside first, the inside of the food relying on the slower conduction of heat. If food is cooked at a high power level, it is possible that the heat may not have reached the centre of the food, so it is hot on the outside but cold in the centre. During standing time heat is transferred to the centre of the food.</p> <ul style="list-style-type: none"> ■ This may leave the food warm in the middle but cool on the outside. When reheating food with different densities, such as plated meals, it is therefore recommended to select a lower power level and lengthen the duration.

Problem solving guide

Problem	Possible cause and remedy
The microwave oven switches itself off during a cooking, reheating or defrosting programme.	There may be insufficient air circulation. ■ Check whether the air inlet or outlet is blocked. Remove any obstruction.
	The appliance switches off automatically in cases of overheating. ■ Cooking can be continued after a cooling-down period.
	If the appliance keeps switching itself off ■ Contact Miele.

Contact in case of fault

In the event of any faults which you cannot remedy yourself, please contact Miele.

The contact details for Miele can be found at the end of these operating instructions.

When contacting Miele, please quote the model and serial number of your appliance.

This information can be found on the data plate, which is located on the inside of the appliance front.

Warranty

The manufacturer's warranty for this appliance is 2 years.

For further information, please refer to your warranty booklet.

Miele Australia Pty. Ltd.

ACN 005 635 398
ABN 96 005 635 398

**Miele Experience Centre and
Head Office Melbourne:**

1 Gilbert Park Drive
Knoxfield, VIC 3180

Miele Experience Centre South Melbourne:

206-210 Coventry Street
South Melbourne, VIC 3205

Miele Experience Centre and Office Sydney:

3 Skyline Place
Frenchs Forest, NSW 2086

Miele Experience Centre and Office Brisbane:

Tenancy 4C, 63 Skyring Terrace
Newstead, QLD 4006

Miele Experience Centre Gold Coast:

131 Ferry Road
Southport, QLD 4215

Miele Experience Centre and Office Adelaide:

83-85 Sir Donald Bradman Drive
Hilton, SA 5033

Miele Experience Centre and Office Perth:

205-207 Stirling Highway
Claremont, WA 6010



www.miele.com.au



Miele New Zealand Limited

IRD 98 463 631

Head Office:

Level 2, 10 College Hill
Freemans Bay, Auckland 1011

**Miele Experience Centre
Auckland:**

8 College Hill
Freemans Bay, Auckland 1011
Telephone:
0800 464 353 (0800 4 MIELE)
www.miele.co.nz

Miele Global Headquarters

Germany

Miele & Cie. KG

Carl-Miele-Straße 29
33332 Gütersloh
Federal Republic of Germany

M 2240 SC

en-AU, NZ

M.-Nr. 11 198 700 / 01